

# **CE EMC TEST REPORT**

**for**

**FINGERTEC SKADEX**

**MODEL: SKADEX**

**Trade Mark: FINGERTEC**

**Test Report Number: WST13090365-1ER**

**Issued Date: Sep. 17, 2013**

**Issued for:**

**FINGERTEC WORLDWIDE SDN BHD.**

**NO. 6, 8 & 10 JALAN BK 3/2 BANDAR KINRARA, 47180 PUCHONG, SELANGOR.**

**Issued By:**

**WST Certification & Testing (HK) Limited**

**12/F., San Toi Building, 137-139 Connaught Road Central, Hong Kong**

**Hong Kong: TEL: +86-0852-2139 3077 FAX: +86-0852-2139 3217**

**Shenzhen office: TEL: +86-0755-2782 2785 FAX: +86-0755-2782 2175**

**E-mail: Michael@wstlab.com**

**Http:// www.wstlab.com**

### TEST RESULT CERTIFICATION

**Applicant's name** ..... : FINGERTEC WORLDWIDE SDN BHD.  
 Address ..... : NO. 6, 8 & 10 JALAN BK 3/2 BANDAR KINRARA, 47180  
 PUCHONG, SELANGOR.

**Manufacture's Name**..... : FINGERTEC WORLDWIDE SDN BHD.  
 Address ..... : NO. 6, 8 & 10 JALAN BK 3/2 BANDAR KINRARA, 47180  
 PUCHONG, SELANGOR.

**Product description**

Trade Mark: FINGERTEC  
 Product name ..... : FINGERTEC SKADEX  
 Model and/or type reference : SKADEX  
 EN 55022:2010  
 EN 55024:2010

**Standards** ..... : EN 61000-3-2:2006+A1:2009+A2:2009  
 EN 61000-3-3:2008

This device described above has been tested by WST, and the test results show that the equipment under test (EUT) is in compliance with the 2004/108/EC requirements. And it is applicable only to the tested sample identified in the report.

This report shall not be reproduced except in full, without the written approval of WST, this document may be altered or revised by WST, personal only, and shall be noted in the revision of the document.

**Date of Test** ..... :  
 Date (s) of performance of tests ..... : Sep. 09, 2013 ~ Sep. 17, 2013  
 Date of Issue ..... : Sep. 17, 2013  
 Test Result ..... : **Pass**

Testing Engineer : Eric Xie  
 (Eric Xie)

Technical Manager : Nico Lee  
 (Nico Lee)

Authorized Signatory : Michael Ling  
 (Michael Ling)

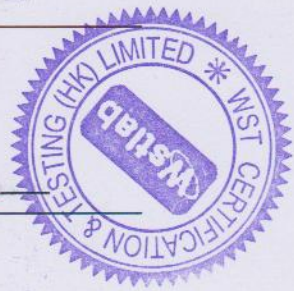

<b>Table of Contents</b>	<b>Page</b>
1 . TEST SUMMARY	6
1.1 TEST FACILITY	7
1.2 MEASUREMENT UNCERTAINTY	7
2 . GENERAL INFORMATION	8
2.1 GENERAL DESCRIPTION OF EUT	8
2.2 DESCRIPTION OF TEST MODES	9
2.3 DESCRIPTION OF TEST SETUP	10
2.4 DESCRIPTION TEST PERIPHERAL AND EUT PERIPHERAL	11
2.5 MEASUREMENT INSTRUMENTS LIST	12
3 . EMC EMISSION TEST	14
3.1 CONDUCTED EMISSION MEASUREMENT	14
3.1.1 POWER LINE CONDUCTED EMISSION	14
3.1.2 TEST PROCEDURE	15
3.1.3 TEST SETUP	15
3.1.4 EUT OPERATING CONDITIONS	15
3.1.5 TEST RESULTS	15
3.2 RADIATED EMISSION MEASUREMENT	15
3.2.1 LIMITS OF RADIATED EMISSION MEASUREMENT	15
3.2.2 LIMITS OF RADIATED EMISSION MEASUREMENT	15
3.2.3 TEST PROCEDURE	15
3.2.4 TEST SETUP	15
3.2.5 EUT OPERATING CONDITIONS	15
3.2.6 TEST RESULTS	15
3.2.7 TEST RESULTS(1000~6000MHz)	15
3.3 HARMONICS CURRENT	15
3.3.1 LIMITS OF HARMONICS CURRENT	15
3.3.1.1 TEST PROCEDURE	15
3.3.1.2 EUT OPERATING CONDITIONS	15
3.3.1.3 TEST SETUP	15
3.3.2 TEST RESULTS	15
3.4 VOLTAGE FLUCTUATION AND FLICKERS	15
3.4.1 LIMITS OF VOLTAGE FLUCTUATION AND FLICKERS	15
3.4.1.1 TEST PROCEDURE	15
3.4.1.2 EUT OPERATING CONDITIONS	15
3.4.1.3 TEST SETUP	15
3.4.2 TEST RESULTS	15

<b>Table of Contents</b>	<b>Page</b>
4 . EMC IMMUNITY TEST	15
4.1 STANDARD COMPLIANCE/SERVURITY LEVEL/CRITERIA	15
4.2 GENERAL PERFORMANCE CRITERIA	15
4.3 GENERAL PERFORMANCE CRITERIA TEST SETUP	15
4.4 ESD TESTING	15
4.4.1 TEST SPECIFICATION	15
4.4.2 TEST PROCEDURE	15
4.4.3 TEST SETUP	15
4.4.4 TEST RESULTS	15
4.5 RS TESTING	15
4.5.1 TEST SPECIFICATION	15
4.5.2 TEST PROCEDURE	15
4.5.3 TEST SETU	15
4.5.4 TEST RESULTS	15
4.6 EFT/BURST TESTING	15
4.6.1 TEST SPECIFICATION	15
4.6.2 TEST PROCEDURE	15
4.6.3 TEST SETUP	15
4.6.4 TEST RESULTS	15
4.7 SURGE TESTING	15
4.7.1 TEST SPECIFICATION	15
4.7.2 TEST PROCEDURE	15
4.7.3 TEST SETUP	15
4.7.4 TEST RESULTS	15
4.8 INJECTION CURRENT TESTING	15
4.8.1 TEST SPECIFICATION	15
4.8.2 TEST PROCEDURE	15
4.8.3 TEST SETUP	15
4.8.4 TEST RESULTS	15
4.9 VOLTAGE INTERRUPTION/DIPS TESTING	15
4.9.1 TEST SPECIFICATION	15
4.9.2 TEST PROCEDURE	15
4.9.3 TEST SETUP	15
4.9.4 TEST RESULTS	15
4.10 VOLTAGE INTERRUPTION/DIPS TESTING	15
4.10.1 TEST SPECIFICATION	15
4.10.2 TEST PROCEDURE	15
4.10.3 TEST SETUP	15
4.10.4 TEST RESULTS	15

**Table of Contents****Page**

5 . EUT TEST PHOTO

15

ATTACHMENT PHOTOGRAPHS OF EUT

15

### 1. TEST SUMMARY

Test procedures according to the technical standards:

EMC Emission				
Standard	Test Item	Limit	Judgment	Remark
EN 55022:2010	Conducted Emission	Class B	PASS	
	Radiated Emission	Class B	PASS	
EN61000-3-2:2006/A2:2009	Harmonic Current Emission	Class A or D NOTE (2)	N/A	
EN 61000-3-3:2008	Voltage Fluctuations & Flicker	-----	N/A	
EMC Immunity				
Section EN 55024:2010	Test Item	Performance Criteria	Judgment	Remark
EN 61000-4-2:2009	Electrostatic Discharge	B	PASS	
EN 61000-4-3:2010	RF electromagnetic field	A	PASS	
EN 61000-4-4:2012	Fast transients	B	N/A	
EN 61000-4-5:2006	Surges	B	N/A	
EN 61000-4-6:2012	Injected Current	A	N/A	
EN 61000-4-8:2010	Power Frequency Magnetic Field	A	N/A	
EN 61000-4-11:2004	Volt. Interruptions Volt. Dips	B / C / C NOTE (3)	N/A	

**NOTE:**

- (1) "N/A" denotes test is not applicable in this Test Report
- (2) The power consumption of EUT is less than 75W and no Limits apply.
- (3) Voltage dip: 100% reduction – Performance Criteria **B**  
 Voltage dip: 30% reduction – Performance Criteria **C**  
 Voltage Interruption: 100% Interruption – Performance Criteria **C**
- (4) For client's request and manual description, the test will not be executed.

1.1 TEST FACILITY

WST Certification & Testing (HK) Limited  
 Address: 12/F., San Toi Building, 137-139 Connaught Road Central, Hong Kong

1.2 MEASUREMENT UNCERTAINTY

The reported uncertainty of measurement  $y \pm U$ , where expanded uncertainty  $U$  is based on a standard uncertainty multiplied by a coverage factor of  $k=2$ , providing a level of confidence of approximately **95 %**.

A. Conducted Measurement :

Test Site	Method	Measurement Frequency Range	U , (dB)	NOTE
WSTC01	ANSI	150 KHz ~ 30MHz	3.2	

B. Radiated Measurement :

Test Site	Method	Measurement Frequency Range	U , (dB)	NOTE
WSTA01	ANSI	30MHz ~ 1000MHz	4.7	
		1GHz ~6GHz	5.0	

## 2. GENERAL INFORMATION

### 2.1 GENERAL DESCRIPTION OF EUT

Equipment	FINGERTEC SKADEX				
Model Name	SKADEX				
Serial No	N/A				
Model Difference	N/A				
Product Description	<p>The EUT is a FINGERTEC SKADEX .</p> <table border="1"><tr><td>Operating frequency:</td><td>N/A</td></tr><tr><td>Connecting I/O port:</td><td>N/A</td></tr></table> <p>Based on the application, features, or specification exhibited in User's Manual, the EUT is considered as an ITE/Computing Device. More details of EUT technical specification, please refer to the User's Manual.</p>	Operating frequency:	N/A	Connecting I/O port:	N/A
Operating frequency:	N/A				
Connecting I/O port:	N/A				
Power Source	DC Voltage				
Power Rating	DC 12V, 3A				



## 2.2 DESCRIPTION OF TEST MODES

To investigate the maximum EMI emission characteristics generated from EUT, the test system was pre-scanning tested based on the consideration of following EUT operation mode or test configuration mode which possibly have effect on EMI emission level. Each of these EUT operation mode(s) or test configuration mode(s) mentioned above was evaluated respectively.

Pretest Mode	Description
Mode 1	Running

For Conducted Test	
Final Test Mode	Description
Mode 1	Running

For Radiated Test	
Final Test Mode	Description
Mode 1	Running

For EMS Test	
Final Test Mode	Description
Mode 1	Running

### 2.3 DESCRIPTION OF TEST SETUP

Mode 1:



2.4 DESCRIPTION TEST PERIPHERAL AND EUT PERIPHERAL

The EUT has been tested as an independent unit together with other necessary accessories or support units. The following support units or accessories were used to form a representative test configuration during the tests.

Item	Equipment	Mfr/Brand	Model/Type No.	Series No.	Note
E-1	FINGERTEC SKADEX	FINGERTE C	SKADEX	N/A	EUT

Item	Shielded Type	Ferrite Core	Length	Note
C-1	NO	NO	120cm	

Note:

- (1) The support equipment was authorized by Declaration of Confirmation.
- (2) For detachable type I/O cable should be specified the length in cm in 『Length』 column.
- (3) “YES” is means “shielded” “with core”; “NO” is means “unshielded” “without core”.

## 2.5 MEASUREMENT INSTRUMENTS LIST

## 2.5.1 CONDUCTED TEST SITE

Item	Kind of Equipment	Manufacturer	Type No.	Serial No.	Calibrated until
1	LISN	R&S	ENV216	101313	Jul. 06, 2014
2	LISN	EMCO	3816/2	00042990	Jul. 06, 2014
3	50Ω Switch	ANRITSU CORP	MP59B	6200983704	Jul. 06, 2014
4	Test Cable	N/A	C01	N/A	Jul. 06, 2014
5	Test Cable	N/A	C02	N/A	Jul. 06, 2014
6	Test Cable	N/A	C03	N/A	Jul. 06, 2014
7	EMI Test Receiver	R&S	ESCI	101160	Jul. 06, 2014
8	Passive Voltage Probe	ESH2-Z3	R&S	100196	Jul. 06, 2014
9	Triple-Loop Antenna	EVERFINE	LIA-2	11020003	Jul. 06, 2014
10	Absorbing Clamp	R&S	MDS-21	100423	Jul. 08, 2014

## 2.5.2 RADIATED TEST SITE

Item	Kind of Equipment	Manufacturer	Type No.	Serial No.	Calibrated until
1	Bilog Antenna	TESEQ	CBL6111D	31216	Jul. 06, 2014
2	Test Cable	N/A	R-01	N/A	Jul. 06, 2014
3	Test Cable	N/A	R-02	N/A	Jul. 06, 2014
4	EMI Test Receiver	R&S	ESCI-7	101318	Jul. 06, 2014
5	Antenna Mast	EM	SC100_1	N/A	N/A
6	Turn Table	EM	SC100	060531	N/A
7	50Ω Switch	Anritsu Corp	MP59B	6200983705	Jul. 06, 2014
8	Spectrum Analyzer	Aglient	E4407B	MY45108040	Jul. 06. 2014
9	Horn Antenna	EM	EM-AH-1018 0	2011071402	Jul. 06. 2014
10	Amplifier	EM	EM-30180	060538	Jul. 06. 2014

## 2.5.3 HARMONICS AND FILCK

Item	Kind of Equipment	Manufacturer	Type No.	Serial No.	Calibrated until
1	Harmonic & Flicker	EM TEST	DPA500	0303-04	Jul. 06, 2014
2	AC Power Source	EM TEST	ACS500	0203-01	Jul. 06, 2014

## 2.5.4 ESD

Item	Kind of Equipment	Manufacturer	Type No.	Serial No.	Calibrated until
1	ESD TEST GENERATOR	EVERFINE	EMS61000-2 A-V200	11040001T	Jul. 06, 2014

## 2.5.5 RS

Item	Kind of Equipment	Manufacturer	Type No.	Serial No.	Calibrated until
1	Signal Generator	R&S	SMT 06	832080/007	Jul. 24, 2014
2	Log-Bicon Antenna	Schwarzbeck	VULB9161	4022	Aug. 15, 2014
3	Power Amplifier	AR	150W1000M1	320946	Sep. 23, 2013
4	Microwave Horn Antenna	AR	AT4002A	321467	Sep. 11, 2014
5	Power Amplifier	AR	25S1G4A	308598	Sep. 23, 2013

## 2.5.6 SURGE, EFT/BURST, VOLTAGE INTERRUPTION/DIPS

Item	Kind of Equipment	Manufacturer	Type No.	Serial No.	Calibrated until
1	Surge Generator	EVERFINE	EMS61000-5 A	1101002	Jul. 06, 2014
2	DIPS Generator	EVERFINE	EMS61000-1 1K	1011002	Jul. 06, 2014
	EFT/B Generator	EVERFINE	EMS61000-4 A-V2	1012005	Aug. 04, 2014

## 2.5.7 INJECTION CURRENT

Item	Kind of Equipment	Manufacturer	Type No.	Serial No.	Calibrated until
1	Signal Generator	IFR	2023A	202301/368	Sep. 30, 2013
2	Power Amplifier	AR	75A250AM1	0320709	Sep. 23, 2013
3	CDN	FCC	FCC-801-M2	06043	Sep. 02, 2014
4	EM Clamp	FCC	F-203I-23MM	504	Sep. 09, 2014

## 2.4.8 MF

Item	Kind of Equipment	Manufacturer	Type No.	Serial No.	Calibrated until
1	Generator	EVERFINE	EMS61000-8 K	1007001	Jul. 06, 2014

### 3. EMC EMISSION TEST

#### 3.1 CONDUCTED EMISSION MEASUREMENT

##### 3.1.1 POWER LINE CONDUCTED EMISSION (Frequency Range 150KHz-30MHz)

FREQUENCY (MHz)	Class A (dBuV)		Class B (dBuV)	
	Quasi-peak	Average	Quasi-peak	Average
0.15 -0.5	79.00	66.00	66 - 56 *	56 - 46 *
0.50 -5.0	73.00	60.00	56.00	46.00
5.0 -30.0	73.00	60.00	60.00	50.00

Note:

- (1) The tighter limit applies at the band edges.
- (2) The limit of " \* " marked band means the limitation decreases linearly with the logarithm of the frequency in the range.

The following table is the setting of the receiver

Receiver Parameters	Setting
Attenuation	10 dB
Start Frequency	0.15 MHz
Stop Frequency	30 MHz
IF Bandwidth	9 kHz

### 3.1.2 TEST PROCEDURE

- a. The EUT was placed 0.4 meters from the horizontal ground plane with EUT being connected to the power mains through a line impedance stabilization network (LISN). All other support equipments powered from additional LISN(s). The LISN provide 50 Ohm/ 50uH of coupling impedance for the measuring instrument.
- b. Interconnecting cables that hang closer than 40 cm to the ground plane shall be folded back and forth in the center forming a bundle 30 to 40 cm long.
- c. I/O cables that are not connected to a peripheral shall be bundled in the center. The end of the cable may be terminated, if required, using the correct terminating impedance. The overall length shall not exceed 1 m.
- d. LISN at least 80 cm from nearest part of EUT chassis.
- e. For the actual test configuration, please refer to the related Item –EUT Test Photos.

### 3.1.3 TEST SETUP

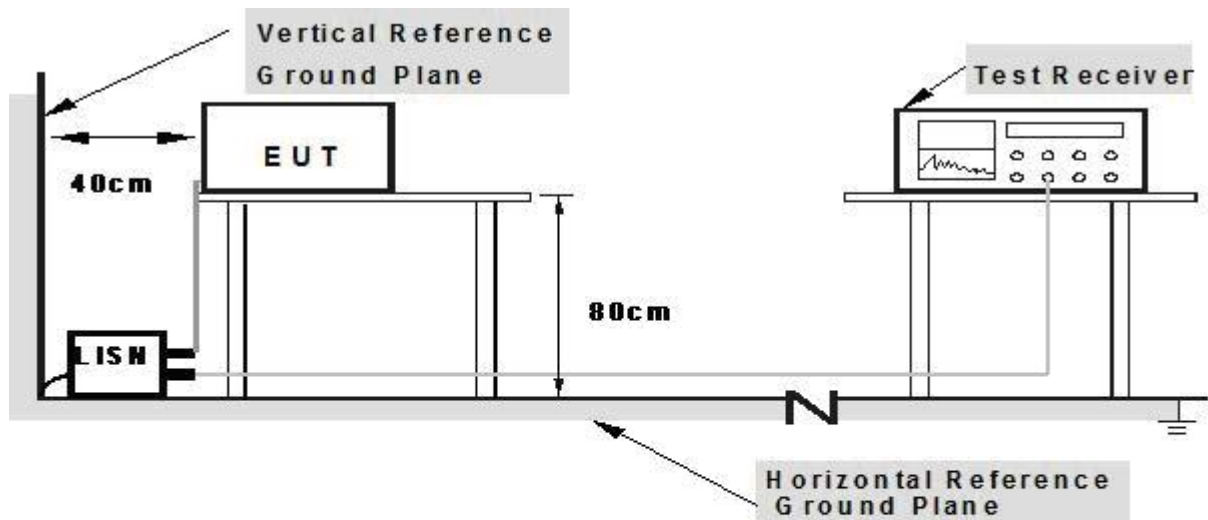

**Note: 1. Support units were connected to second LISN.**

**2. Both of LISNs (AMN) are 80 cm from EUT and at least 80 cm from other units and other metal planes**

### 3.1.4 EUT OPERATING CONDITIONS

The EUT tested system was configured as the statements of 2.3 Unless otherwise a special operating condition is specified in the follows during the testing.

### 3.1.5 TEST RESULTS

EUT :	FINGERTEC SKADEX	Model Name. :	SKADEX
Temperature :	26 °C	Relative Humidity :	54%
Pressure :	1010hPa	Test Date :	2013-09-13
Test Mode :	Running	Phase :	L
Test Voltage :	DC 12V, 3A		

No.	Mk.	Freq. MHz	Reading Level dBuV	Correct Factor dB	Measure- ment dBuV	Limit dBuV	Over dB	Detector	Comment
1		0.2459	37.35	10.46	47.81	61.89	-14.08	QP	
2		0.2459	32.38	10.46	42.84	51.89	-9.05	AVG	
3		0.3699	33.05	10.55	43.60	58.50	-14.90	QP	
4		0.3699	32.23	10.55	42.78	48.50	-5.72	AVG	
5		0.4939	31.00	10.41	41.41	56.10	-14.69	QP	
6		0.4939	29.02	10.41	39.43	46.10	-6.67	AVG	
7		0.6139	32.94	10.73	43.67	56.00	-12.33	QP	
8		0.6139	29.15	10.73	39.88	46.00	-6.12	AVG	
9		0.9859	33.42	10.78	44.20	56.00	-11.80	QP	
10		0.9859	28.32	10.78	39.10	46.00	-6.90	AVG	
11		1.9739	33.81	10.71	44.52	56.00	-11.48	QP	
12	*	1.9739	29.95	10.71	40.66	46.00	-5.34	AVG	

**Remark:**

1. All readings are Quasi-Peak and Average values.
2. Factor = Antenna Factor + Cable Loss.
3. N/A means All Data have pass Limit

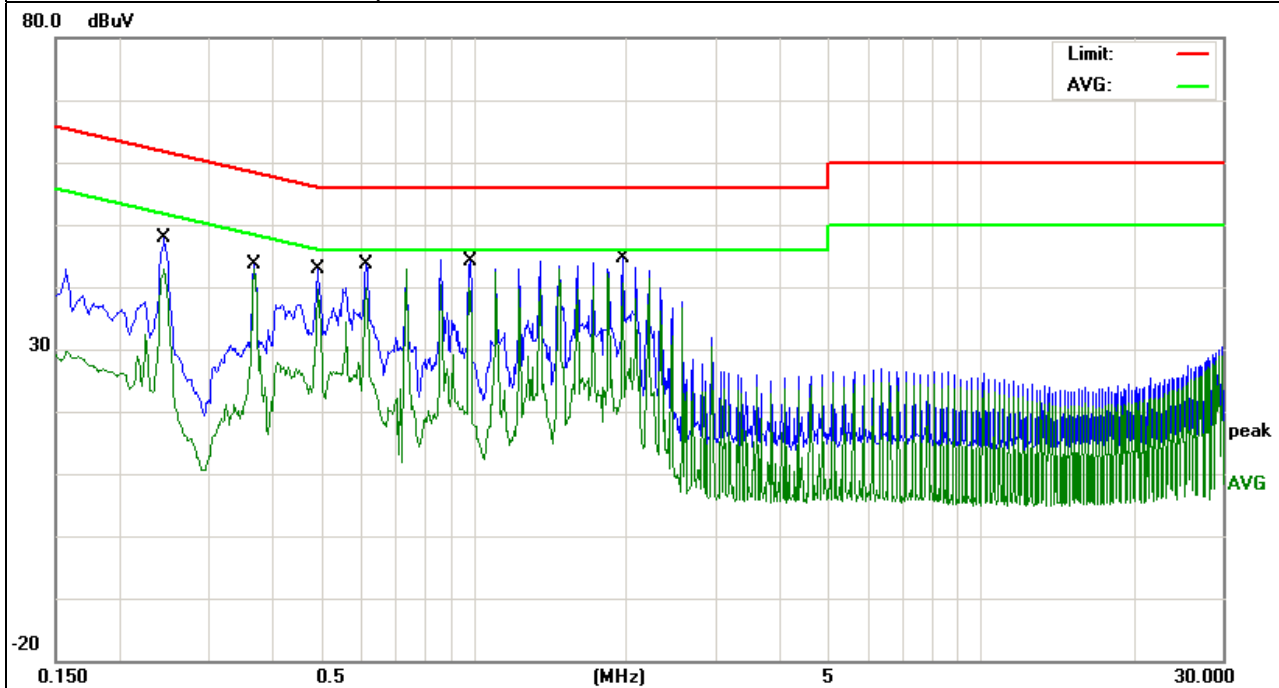



EUT :	FINGERTEC SKADEX	Model Name. :	SKADEX
Temperature :	26 °C	Relative Humidity :	54%
Pressure :	1010hPa	Test Date :	2013-09-13
Test Mode :	Running	Phase :	N
Test Voltage :	DC 12V, 3A		

No.	Mk.	Freq. MHz	Reading Level dBuV	Correct Factor dB	Measure- ment dBuV	Limit dBuV	Over dB	Detector	Comment
1		0.2460	35.79	10.46	46.25	61.89	-15.64	QP	
2		0.2460	30.54	10.46	41.00	51.89	-10.89	AVG	
3		0.3700	32.74	10.54	43.28	58.50	-15.22	QP	
4		0.3700	32.39	10.54	42.93	48.50	-5.57	AVG	
5		0.4940	32.79	10.41	43.20	56.10	-12.90	QP	
6	*	0.4940	31.23	10.41	41.64	46.10	-4.46	AVG	
7		0.6140	34.31	10.73	45.04	56.00	-10.96	QP	
8		0.6140	30.67	10.73	41.40	46.00	-4.60	AVG	
9		0.8620	33.28	10.78	44.06	56.00	-11.94	QP	
10		0.8620	29.05	10.78	39.83	46.00	-6.17	AVG	
11		1.3540	33.21	10.74	43.95	56.00	-12.05	QP	
12		1.3540	28.98	10.74	39.72	46.00	-6.28	AVG	

Remark:

1. All readings are Quasi-Peak and Average values.
2. Factor = Antenna Factor + Cable Loss.
3. N/A means All Data have pass Limit

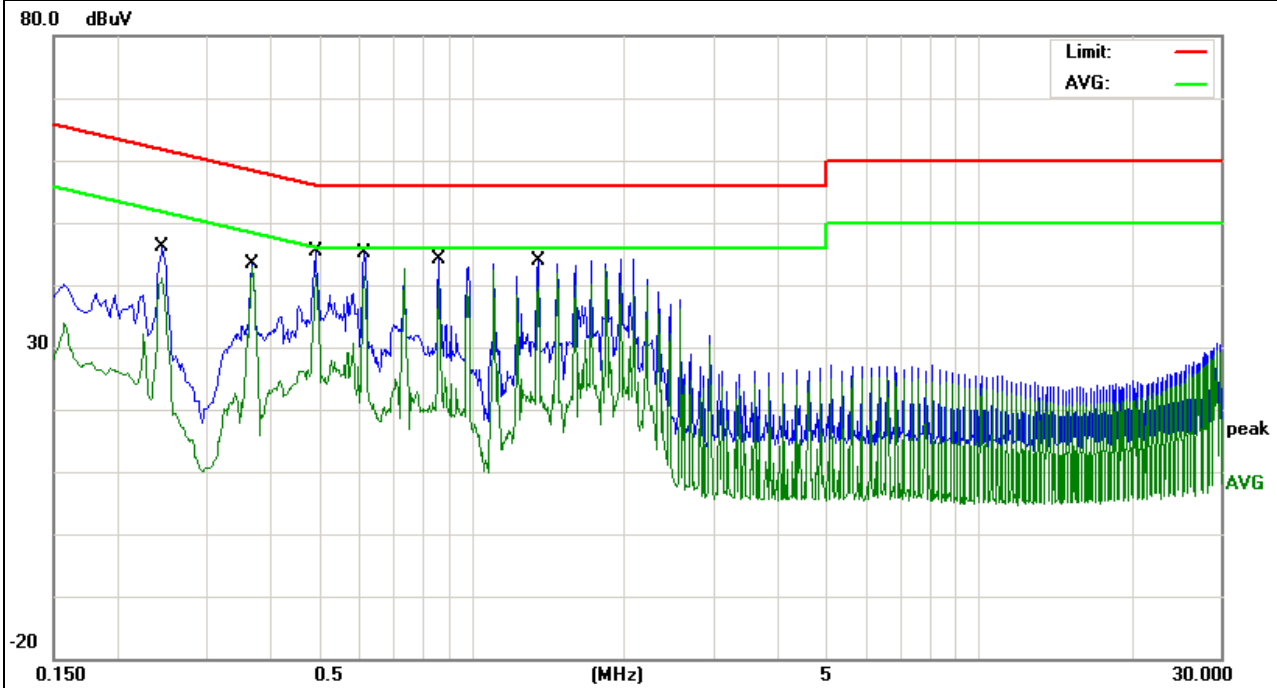

### 3.2 RADIATED EMISSION MEASUREMENT

#### 3.2.1 LIMITS OF RADIATED EMISSION MEASUREMENT (Below 1000MHz)

FREQUENCY (MHz)	Class A		Class B	
	At 10m	At 3m	At 10m	At 3m
	dBuV/m	dBuV/m	dBuV/m	dBuV/m
30 – 230	40	50	30	40
230 – 1000	47	57	37	47

#### 3.2.2 LIMITS OF RADIATED EMISSION MEASUREMENT (Above 1000MHz)

FREQUENCY (MHz)	Class A (at 3m) dBuV/m		Class B (at 3m) dBuV/m	
	Peak	Avg	Peak	Avg
1000-3000	76	56	70	50
3000-6000	80	60	74	54

Notes:

- (1) The limit for radiated test was performed according to as following:  
CISPR 22.
- (2) The tighter limit applies at the band edges.
- (3) Emission level (dBuV/m)=20log Emission level (uV/m).

#### 3.2.3 TEST PROCEDURE

- a. The measuring distance of at 10 m shall be used for measurements at frequency up to 1GHz. For frequencies above 1GHz, any suitable measuring distance may be used.
- b. The EUT was placed on the top of a rotating table 0.8 meters above the ground at a 10 meter open area test site. The table was rotated 360 degrees to determine the position of the highest radiation.
- c. The height of the equipment or of the substitution antenna shall be 0.8 m; the height of the test antenna shall vary between 1 m to 4 m. Both horizontal and vertical polarizations of the antenna are set to make the measurement.
- d. The initial step in collecting conducted emission data is a spectrum analyzer peak detector mode pre-scanning the measurement frequency range. Significant peaks are then marked and then Quasi Peak detector mode re-measured, above 1G Average detector mode will be instead.
- e. If the Peak Mode measured value compliance with and lower than Quasi Peak Mode Limit, the EUT shall be deemed to meet QP(AV) Limits and then no additional QP Mode measurement performed.
- f. For the actual test configuration, please refer to the related Item –EUT Test Photos.

### 3.2.4 TEST SETUP

#### (A) Radiated Emission Test Set-Up Frequency Below 1 GHz

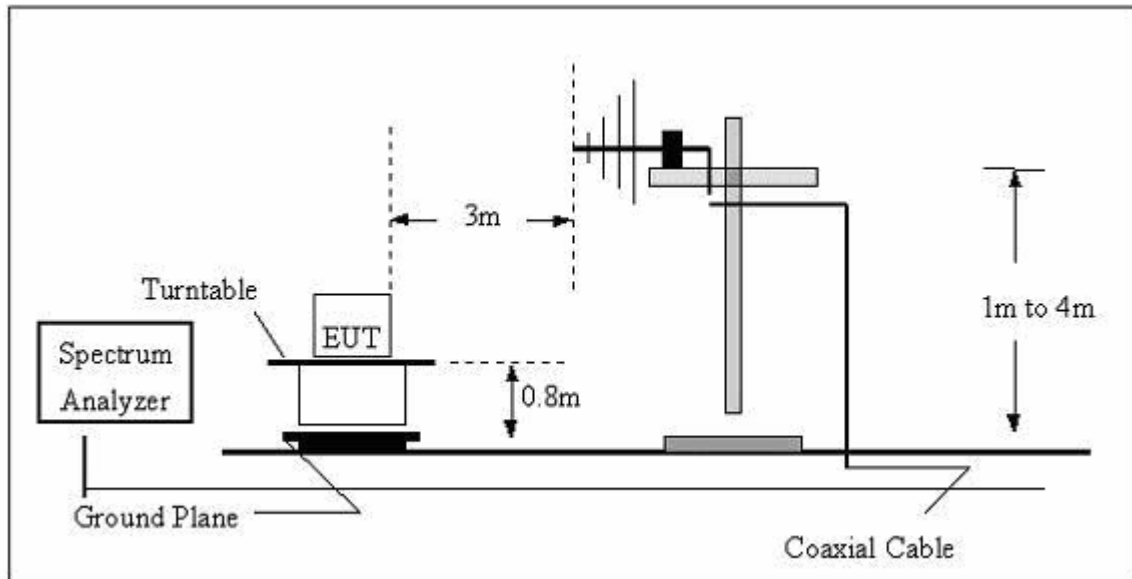

#### (B) Radiated Emission Test Set-Up Frequency Above 1GHz

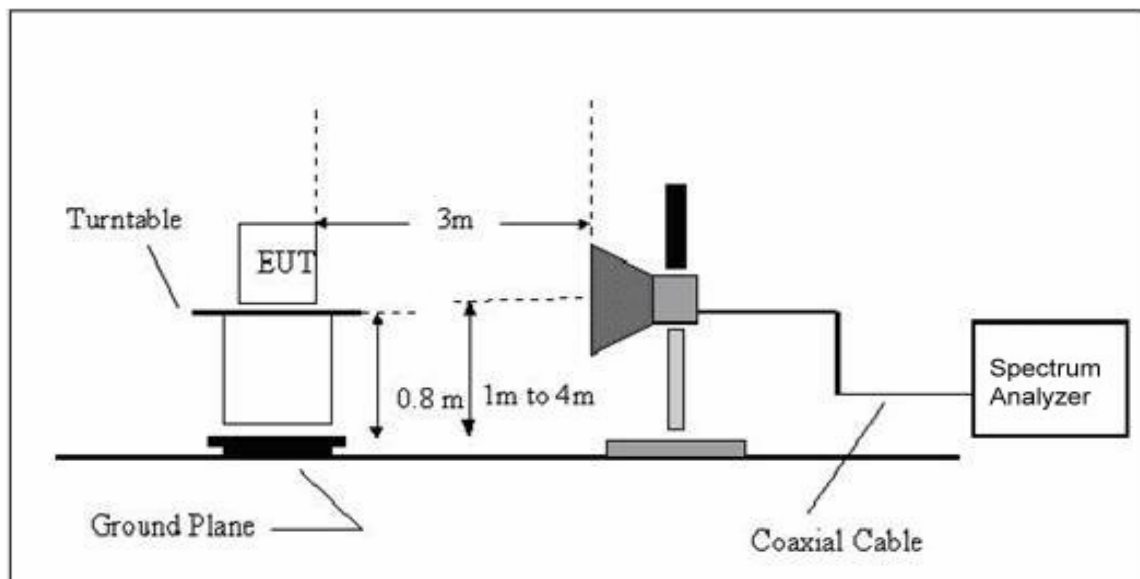

### 3.2.5 EUT OPERATING CONDITIONS

The EUT tested system was configured as the statements of 2.3 Unless otherwise a special operating condition is specified in the follows during the testing.

### 3.2.6 TEST RESULTS

EUT :	FINGERTEC SKADEX	Model Name :	SKADEX
Temperature :	24 °C	Relative Humidity :	54%
Pressure :	1010 hPa	Test Date :	2013-09-13
Test Mode :	Running	Polarization :	Horizontal
Test Power :	DC 12V, 3A		

No.	Mk.	Freq. MHz	Reading Level dBuV	Correct Factor dB	Measure- ment dBuV/m	Limit dBuV/m	Over dB	Antenna Height cm	Table Degree degree	Comment
1		86.5027	41.63	-9.65	31.98	40.00	-8.02	QP		
2	*	261.0581	46.26	-4.96	41.30	47.00	-5.70	QP		
3		375.9384	41.74	-2.73	39.01	47.00	-7.99	QP		
4		480.5276	41.47	-2.44	39.03	47.00	-7.97	QP		
5		601.4265	37.77	1.67	39.44	47.00	-7.56	QP		
6		656.5298	35.46	5.49	40.95	47.00	-6.05	QP		

**Remark:**

1. All readings are Quasi-Peak and Average values.
2. Factor = Antenna Factor + Cable Loss.
3. N/A means All Data have pass Limit

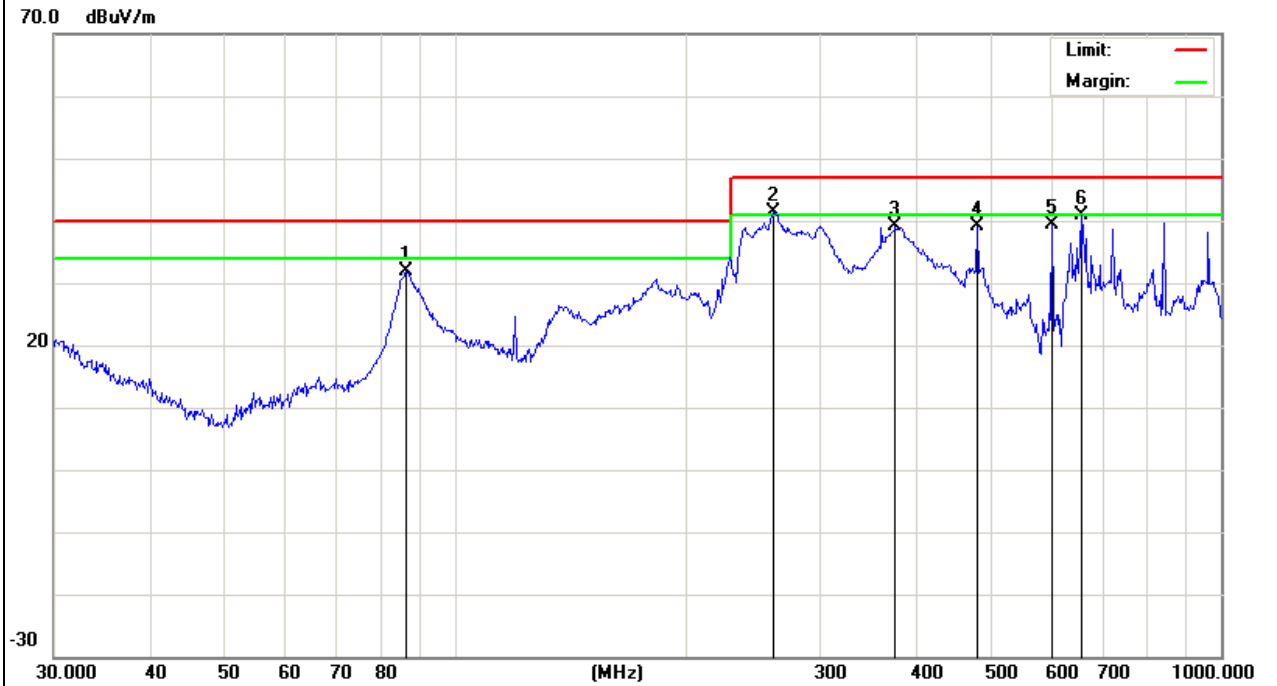

EUT :	FINGERTEC SKADEX	Model Name :	SKADEX
Temperature :	24 °C	Relative Humidity :	54%
Pressure :	1010 hPa	Test Date :	2013-09-13
Test Mode :	Running	Polarization :	Vertical
Test Power :	DC 12V, 3A		

No.	Mk.	Freq. MHz	Reading Level dBuV	Correct Factor dB	Measure- ment dBuV/m	Limit dBuV/m	Over dB	Antenna Height cm	Table Degree degree	Comment
1		85.8983	38.80	-10.69	28.11	40.00	-11.89	QP		
2		260.1444	38.46	-3.50	34.96	47.00	-12.04	QP		
3		385.2805	39.76	-0.91	38.85	47.00	-8.15	QP		
4	*	480.5276	42.04	-2.44	39.60	47.00	-7.40	QP		
5		721.7259	34.23	3.36	37.59	47.00	-9.41	QP		
6		842.1295	32.54	4.51	37.05	47.00	-9.95	QP		

Remark:

1. All readings are Quasi-Peak and Average values.
2. Factor = Antenna Factor + Cable Loss.
3. N/A means All Data have pass Limit

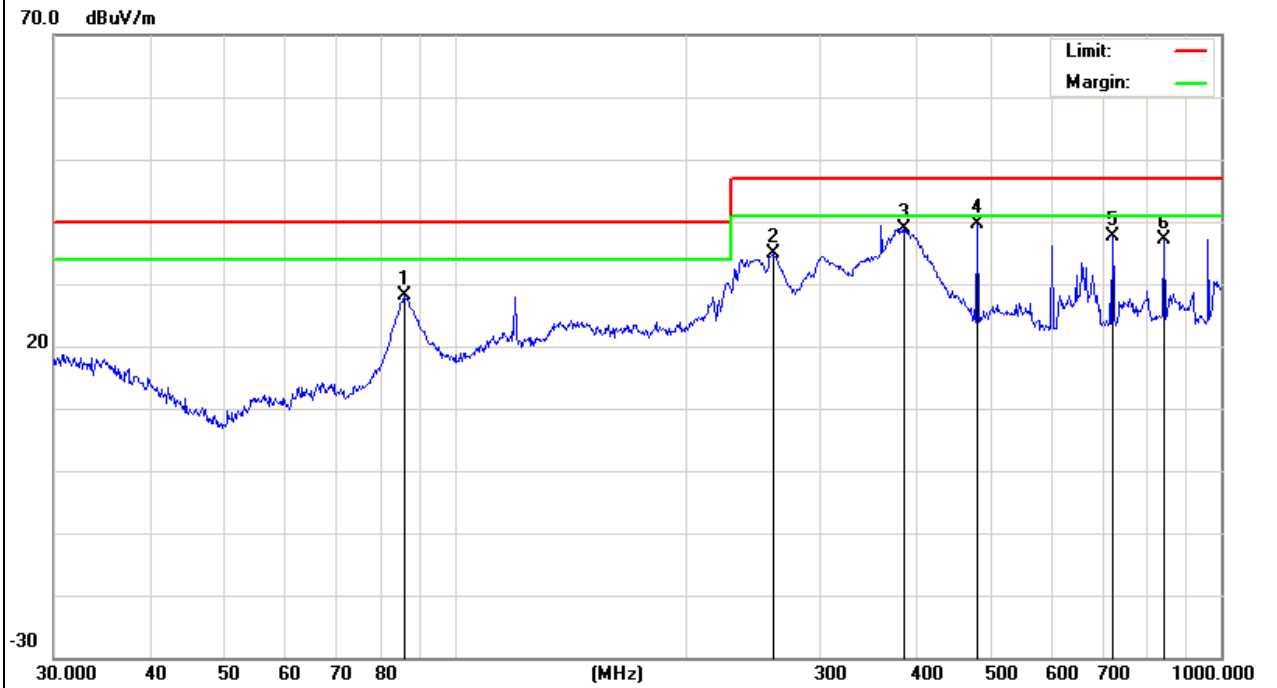

## 3.2.7 TEST RESULTS(1000~6000MHz)

EUT :	FINGERTEC SKADEX	Model Name :	SKADEX
Temperature :	24 °C	Relative Humidity :	54%
Pressure :	1010 hPa	Test Date :	N/A
Test Mode :	N/A	Polarization :	N/A
Test Power :	N/A		

### 3.3 HARMONICS CURRENT

#### 3.3.1 LIMITS OF HARMONICS CURRENT

IEC 555-2					
Table - I			Table - II		
Equipment Category	Harmonic Order n	Max. Permissible Harmonic Current (in Amperes)	Equipment Category	Harmonic Order n	Max. Permissible Harmonic Current (in Amperes)
Non Portable Tools or TV Receivers	Odd Harmonics		TV Receivers	Odd Harmonics	
	3	2.30		3	0.80
	5	1.14		5	0.60
	7	0.77		7	0.45
	9	0.40		9	0.30
	11	0.33		11	0.17
	13	0.21		13	0.12
	$15 \leq n \leq 39$	$0.15 \cdot 15/n$		$15 \leq n \leq 39$	$0.10 \cdot 15/n$
	Even Harmonics			Even Harmonics	
	2	1.08		2	0.30
4	0.43	4	0.15		
8	0.30				
$8 \leq n \leq 40$	$0.23 \cdot 8/n$	DC	0.05		

EN 61000-3-2/IEC 61000-3-2					
Equipment Category	Max. Permissible Harmonic Current (in Amperes)	Equipment Category	Harmonic Order n	Max. Permissible Harmonic Current (in A)	Max. Permissible Harmonic Current (mA/w)
Class A	Same as Limits Specified in 4-2.1, Table - I, but only odd harmonics required	Class D	3	2.30	3.4
			5	1.14	1.9
			7	0.77	1.0
			9	0.40	0.5
			11	0.33	0.35
			$13 \leq n \leq 39$	see Table I	$3.85/n$
only odd harmonics required					

### 3.3.1.1 TEST PROCEDURE

a. The EUT was placed on the top of a wooden table 0.8 meters above the ground and operated to produce the maximum harmonic components under normal operating conditions.

b. The classification of EUT is according to section 5 of EN 61000-3-2. The EUT is classified as follows:

Class A: Balanced three-phase equipment, Household appliances excluding equipment as Class D, Tools excluding portable tools, Dimmers for incandescent lamps, audio equipment, equipment not specified in one of the three other classes.

Class B: Portable tools. Portable tools.; Arc welding equipment which is not professional equipment.

Class C: Lighting equipment.

Class D: Equipment having a specified power less than or equal to 600 W of the following types: Personal computers and personal computer monitors and television receivers.

c. The correspondent test program of test instrument to measure the current harmonics emanated from EUT is chosen. The measure time shall be not less than the time necessary for the EUT to be exercised.

### 3.3.1.2 EUT OPERATING CONDITIONS

The EUT tested system was configured as the statements of **2.3** Unless otherwise a special operating condition is specified in the follows during the testing.

### 3.3.1.3 TEST SETUP

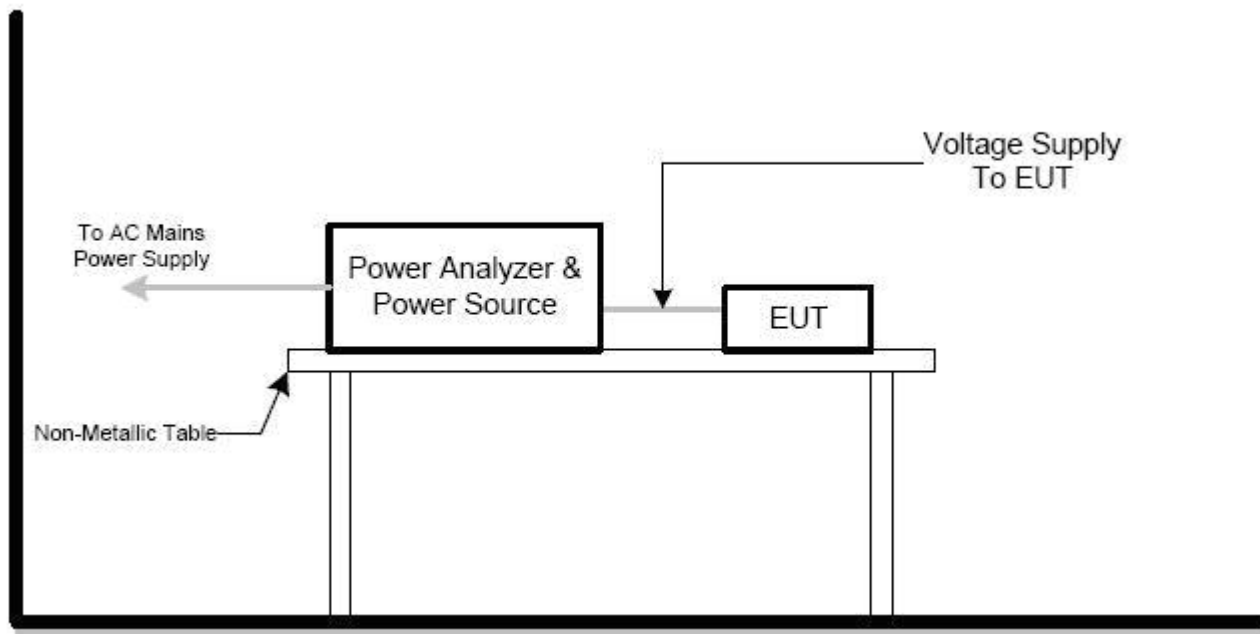



## 3.3.2 TEST RESULTS

EUT :	FINGERTEC SKADEX	Model Name :	SKADEX
Temperature :	24 °C	Relative Humidity :	54%
Pressure :	1010 hPa	Test Date :	N/A
Test Mode :	N/A	Polarization :	N/A
Test Power :	N/A		

## Note:

- 1) N/A - denotes test is not applicable in this test report
- 2) There was not any unintentional transmission in standby mode

### 3.4 VOLTAGE FLUCTUATION AND FLICKERS

#### 3.4.1 LIMITS OF VOLTAGE FLUCTUATION AND FLICKERS

Tests	Limits		Descriptions
	IEC555-3	IEC/EN 61000-3-3	
Pst	≤ 1.0, Tp= 10 min.	≤ 1.0, Tp= 10 min.	Short Term Flicker Indicator
Plt	N/A	≤ 0.65, Tp=2 hr.	Long Term Flicker Indicator
dc	≤ 3%	≤ 3.3%	Relative Steady-State V-Chang
dmax	≤ 4%	≤ 4%	Maximum Relative V-change
d (t)	N/A	≤ 3.3% for > 500 ms	Relative V-change characteristic

##### 3.4.1.1 TEST PROCEDURE

###### a. Harmonic Current Test:

Test was performed according to the procedures specified in Clause 5.0 of IEC555-2 and/or Sub-clause 6.2 of IEC/EN 61000-3-2 depend on which standard adopted for compliance measurement.

###### b. Fluctuation and Flickers Test:

Tests was performed according to the Test Conditions/Assessment of Voltage Fluctuations specified in Clause 5.0/6.0 of IEC555-3 and/or Clause 6.0/4.0 of IEC/EN 61000-3-3 depend on which standard adopted for compliance measurement.

c. All types of harmonic current and/or voltage fluctuation in this report are assessed by direct measurement using flicker-meter.

##### 3.4.1.2 EUT OPERATING CONDITIONS

The EUT tested system was configured as the statements of **2.3** Unless otherwise a special operating condition is specified in the follows during the testing.

##### 3.4.1.3 TEST SETUP

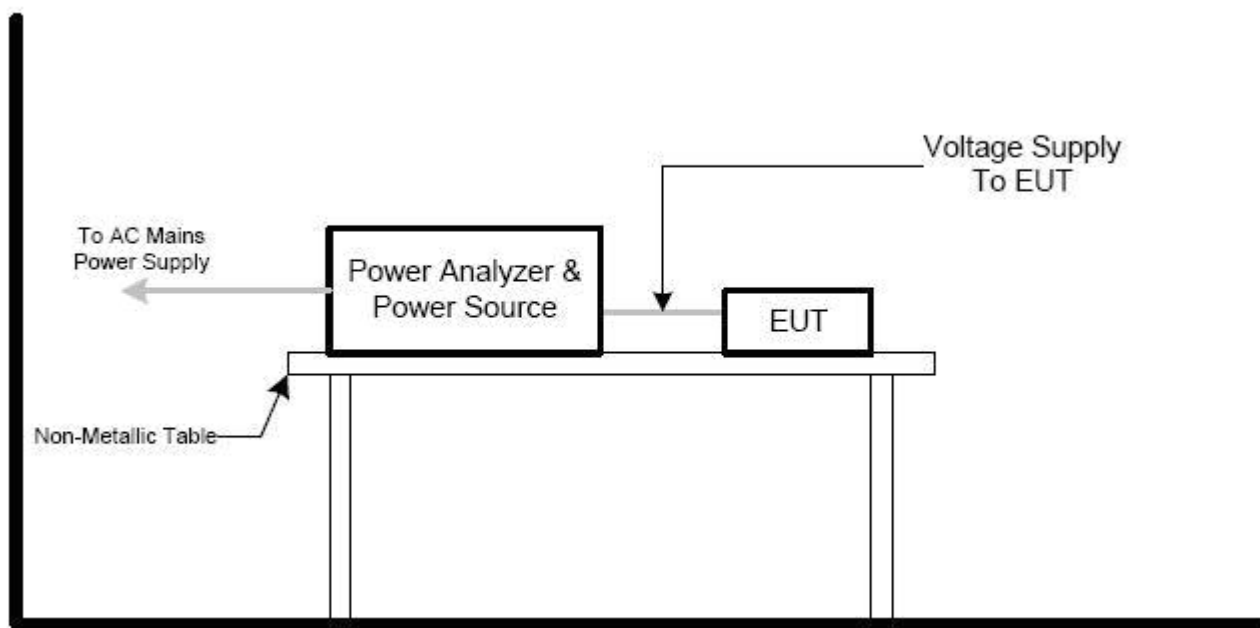

## 3.4.2 TEST RESULTS

EUT :	FINGERTEC SKADEX	Model Name :	SKADEX
Temperature :	24 °C	Relative Humidity :	54%
Pressure :	1010 hPa	Test Date :	N/A
Test Mode :	N/A	Polarization :	N/A
Test Power :	N/A		

## Note:

- 1) N/A - denotes test is not applicable in this test report
- 2) There was not any unintentional transmission in standby mode

#### 4. EMC IMMUNITY TEST

##### 4.1 STANDARD COMPLIANCE/SERVIRITY LEVEL/CRITERIA

Tests Standard No.	TEST SPECIFICATION	Test Mode Test Ports	Perform. Criteria
1. ESD IEC/EN 61000-4-2	8KV air discharge 4KV contact discharge	Direct Mode	B
	4KV HCP discharge 4KV VCP discharge	Indirect Mode	B
2. RS IEC/EN 61000-4-3	80 MHz to 1000 MHz, 1000Hz, 80%, AM modulated	Enclosure	A
3. EFT/Burst IEC/EN 61000-4-4	5/50ns Tr/Th 5KHz Repetition Freq.	Power Supply Port	B
	5/50ns Tr/Th 5KHz Repetition Freq.	CTL/Signal Data Line Port	B
4. Surges IEC/EN 61000-4-5	1.2/50(8/20) Tr/Th us	L-N	B
	1.2/50(8/20) Tr/Th us	L-PE N-PE	B
5 Injected Current IEC/EN 61000-4-6	0.15 MHz to 80 MHz, 1000Hz 80% , AM Modulated 150Ω source impedance	CTL/Signal Port	A
	0.15 MHz to 80 MHz, 1000Hz 80% , AM Modulated 150Ω source impedance	AC Power Port	A
	0.15 MHz to 80 MHz, 1000Hz 80% , AM Modulated 150Ω source impedance	DC Power Port	A
6. Power Frequency Magnetic Field IEC/EN 61000-4-8	50 Hz,	Enclosure	A
7. Volt. Interruptions Volt. Dips IEC/EN 61000-4-11	Voltage dip 100%		B
	Voltage dip 30%	AC Power Port	C
	Interruption 100%		C

## 4.2 GENERAL PERFORMANCE CRITERIA

According to **EN 55024** standard, the general performance criteria as following:

<b>Criterion A</b>	<p>The equipment shall continue to operate as intended without operator intervention. No degradation of performance or loss of function is allowed below a performance level specified by the manufacturer when the equipment is used as intended.</p> <p>The performance level may be replaced by a permissible loss of performance. If the minimum performance level or the permissible performance loss is not specified by the manufacturer, then either of these may be derived from the product description and documentation, and by what the user may reasonably expect from the equipment if used as intended.</p>
<b>Criterion B</b>	<p>After the test, the equipment shall continue to operate as intended without operator intervention. No degradation of performance or loss of function is allowed, after the application of the phenomena below a performance level specified by the manufacturer, when the equipment is used as intended.</p> <p>The performance level may be replaced by a permissible loss of performance. During the test, degradation of performance is allowed. However, no change of operating state or stored data is allowed to persist after the test.</p>
<b>Criterion C</b>	<p>Loss of function is allowed, provided the function is self-recoverable, or can be restored by the operation of the controls by the user in accordance with the manufacturer's instructions.</p> <p>Functions, and/or information stored in non-volatile memory, or protected by a battery backup, shall not be lost.</p>

## 4.3 GENERAL PERFORMANCE CRITERIA TEST SETUP

The EUT tested system was configured as the statements of **2.3** Unless otherwise a special operating condition is specified in the follows during the testing.

## 4.4 ESD TESTING

### 4.4.1 TEST SPECIFICATION

Basic Standard:	IEC/EN 61000-4-2
Discharge Impedance:	330 ohm / 150 pF
Required Performance	B
Discharge Voltage:	Air Discharge : 2kV/4kV/8kV (Direct) Contact Discharge : 2kV/4kV (Direct/Indirect)
Polarity:	Positive & Negative
Number of Discharge:	Air Discharge: min. 20 times at each test point Contact Discharge: min. 200 times in total
Discharge Mode:	Single Discharge
Discharge Period:	1 second minimum

### 4.4.2 TEST PROCEDURE

The test generator necessary to perform direct and indirect application of discharges to the EUT in the following manner:

- a. Contact discharge was applied to conductive surfaces and coupling planes of the EUT.
 

During the test, it was performed with single discharges. For the single discharge time between successive single discharges was at least 1 second. The EUT shall be exposed to at least 200 discharges, 100 each at negative and positive polarity, at a minimum of four test points. One of the test points shall be subjected to at least 50 indirect discharges to the center of the front edge of the horizontal coupling plane. The remaining three test points shall each receive at least 50 direct contact discharges.

If no direct contact test points are available, then at least 200 indirect discharges shall be applied in the indirect mode. Test shall be performed at a maximum repetition rate of one discharge per second.

**Vertical Coupling Plane (VCP):**  
The coupling plane, of dimensions 0.5m x 0.5m, is placed parallel to, and positioned at a distance 0.1m from, the EUT, with the Discharge Electrode touching the coupling plane. The four faces of the EUT will be performed with electrostatic discharge.

**Horizontal Coupling Plane (HCP):**  
The coupling plane is placed under to the EUT. The generator shall be positioned vertically at a distance of 0.1m from the EUT, with the Discharge Electrode touching the coupling plane. The four faces of the EUT will be performed with electrostatic discharge.
- b. Air discharges at insulation surfaces of the EUT.
 

It was at least ten single discharges with positive and negative at the same selected point.

#### 4.4.3 TEST SETUP

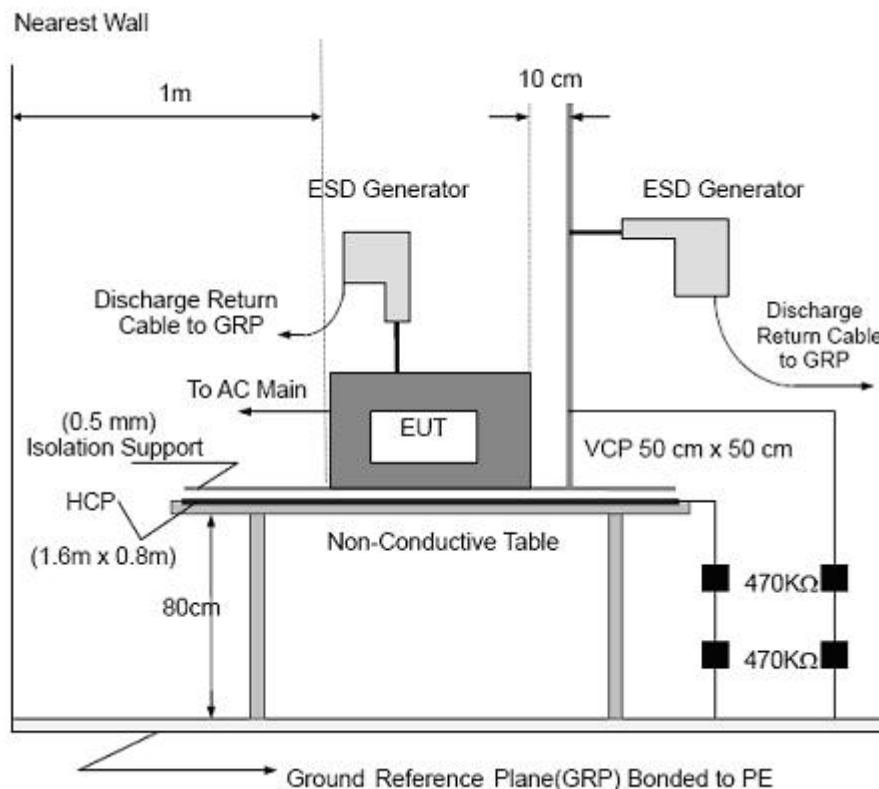

#### Note:

##### TABLE-TOP EQUIPMENT

The configuration consisted of a wooden table 0.8 meters high standing on the Ground Reference Plane. The GRP consisted of a sheet of aluminum at least 0.25mm thick, and 2.5 meters square connected to the protective grounding system. A Horizontal Coupling Plane (1.6m x 0.8m) was placed on the table and attached to the GRP by means of a cable with 940k total impedance. The equipment under test, was installed in a representative system as described in section 7 of IEC /EN 61000-4-2, and its cables were placed on the HCP and isolated by an insulating support of 0.5mm thickness. A distance of 1-meter minimum was provided between the EUT and the walls of the laboratory and any other metallic structure.

##### FLOOR-STANDING EQUIPMENT

The equipment under test was installed in a representative system as described in section 7 of IEC/EN 61000-4-2, and its cables were isolated from the Ground Reference Plane by an insulating support of 0.1-meter thickness. The GRP consisted of a sheet of aluminum that is at least 0.25mm thick, and 2.5meters square connected to the protective grounding system and extended at least 0.5 meters from the EUT on all sides.

4.4.4 TEST RESULTS

EUT :	FINGERTEC SKADEX	Model Name :	SKADEX
Temperature :	25 °C	Relative Humidity :	45%
Pressure :	1010 hPa	Test Date :	2013-09-12
Test Mode :	Running		
Test Power :	DC 12V, 3A		

Mode	Air Discharge								Contact Discharge								Criterion	Result
	4		8		10		15		2		4		6		8			
Test level (kV)																		
Test Location	+	-	+	-	+	-	+	-	+	-	+	-	+	-	+	-		
HCP									A	A	A	A					<b>B</b>	<b>PASS</b>
VCP									A	A	A	A						<b>PASS</b>
Metallic parts									A	A	A	A						<b>PASS</b>
enclosure	A	A	A	A														<b>PASS</b>
slit	A	A	A	A														<b>PASS</b>

Note:

- 1) +/- denotes the Positive/Negative polarity of the output voltage.
- 2) Test condition:  
 Direct / Indirect (HCP/VCP) discharges: Minimum 50 times (Positive/Negative) at each point. Air discharges: Minimum 10 times (Positive/Negative) at each point.
- 3) Test location(s) in which discharge (Air and contact discharge) to be applied illustrated by photos shown in next page(s)
- 4) The Indirect (HCP/VCP) discharges description of test point as following:  
 1.left side 2.right side 3.front side 4.rear side
- 5) N/A - denotes test is not applicable in this test report



## 4.5 RS TESTING

### 4.5.1 TEST SPECIFICATION

Basic Standard:	IEC/EN 61000-4-3
Required Performance	A
Frequency Range:	80 MHz - 1000 MHz
Field Strength:	3 V/m
Modulation:	1kHz Sine Wave, 80%, AM Modulation
Frequency Step:	1 % of fundamental
Polarity of Antenna:	Horizontal and Vertical
Test Distance:	3 m
Antenna Height:	1.5 m
Dwell Time:	at least 3 seconds

### 4.5.2 TEST PROCEDURE

The EUT and support equipment, which are placed on a table that is 0.8 meter above ground and the testing was performed in a fully-anechoic chamber.

The testing distance from antenna to the EUT was 3 meters.

The other condition as following manner:

- a. The frequency range is swept from 80 MHz to 1000 MHz, & 1400MHz - 2700MHz with the signal 80%amplitude modulated with a 1kHz sine wave. The rate of sweep did not exceed 1.5x 10<sup>-3</sup> decade/s. Where the frequency range is swept incrementally, the step size was 1% of fundamental.
- b. Sweep Frequency 900 MHz, with the Duty Cycle:1/8 and Modulation: Pulse 217 Hz(if applicable)
- c. The dwell time at each frequency shall be not less than the time necessary for the EUT to be able to respond.
- d. The test was performed with the EUT exposed to both vertically and horizontally polarized fields on each of the four sides.

## 4.5.3 TEST SETU

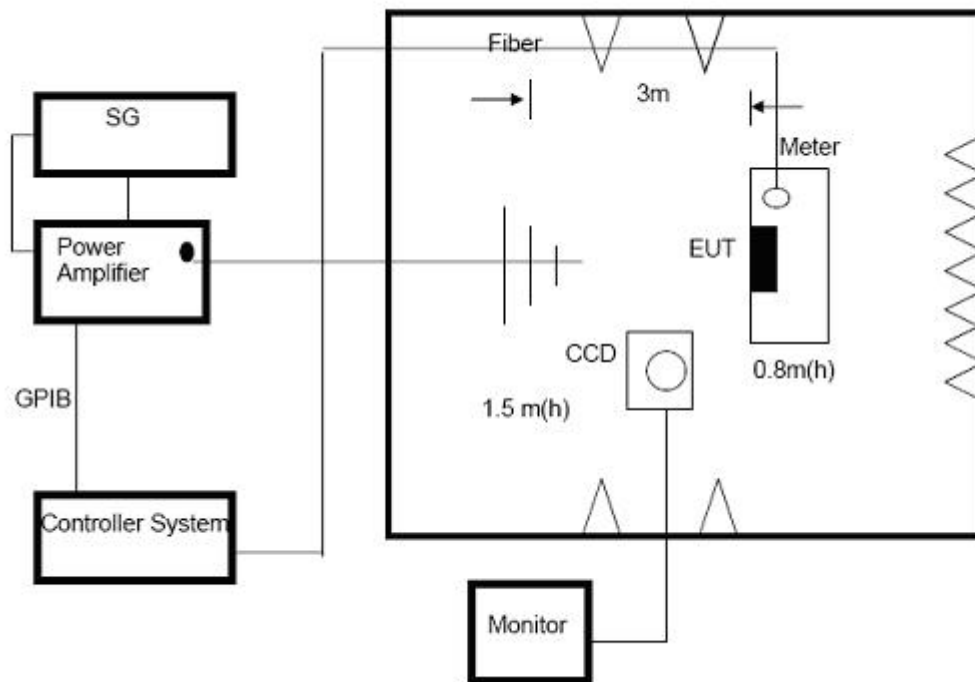

## Note:

## TABLE-TOP EQUIPMENT

The EUT installed in a representative system as described in section 7 of IEC/EN 61000-4-3 was placed on a non-conductive table 0.8 meters in height. The system under test was connected to the power and signal wire according to relevant installation instructions.

## FLOOR-STANDING EQUIPMENT

The EUT installed in a representative system as described in section 7 of IEC/EN 61000-4-3 was placed on a non-conductive wood support 0.1 meters in height. The system under test was connected to the power and signal wire according to relevant installation instructions.

4.5.4 TEST RESULTS

EUT :	FINGERTEC SKADEX	Model Name :	SKADEX
Temperature :	25 °C	Relative Humidity :	60%
Pressure :	1010 hPa	Test Date :	2013-09-12
Test Mode :	Running		
Test Power :	DC 12V, 3A		

Frequency Range (MHz)	RF Field Position	R.F. Field Strength	Azimuth	Perform. Criteria	Results	Judgment
80MHz - 1000MHz	H / V	3 V/m (rms) AM Modulated 1000Hz, 80%	Front	<b>A</b>	<b>A</b>	<b>PASS</b>
			Rear			
			Left			
			Right			

Note:

- 1) N/A - denotes test is not applicable in this test report.
- 2) Criteria A: There was no change operated with initial operating during the test.
- 3) Criteria B: The EUT function loss during the test, but self-recoverable after the test.
- 4) Criteria C: The system shut down during the test.

## 4.6 EFT/BURST TESTING

### 4.6.1 TEST SPECIFICATION

Basic Standard:	IEC/EN 61000-4-4
Required Performance	B
Test Voltage:	Power Line : 1 kV Signal/Control Line : 0.5 KV
Polarity:	Positive & Negative
Impulse Frequency:	5 kHz
Impulse Wave shape :	5/50 ns
Burst Duration:	15 ms
Burst Period:	300 ms
Test Duration:	Not less than 1 min.

### 4.6.2 TEST PROCEDURE

The EUT and support equipment, are placed on a table that is 0.8 meter above a metal ground plane measured 1m\*1m min. and 0.65mm thick min.

The other condition as following manner:

- a. The length of power cord between the coupling device and the EUT should not exceed 1 meter.
- b. Both positive and negative polarity discharges were applied.
- c. The duration time of each test sequential was 1 minute

## 4.6.3 TEST SETUP

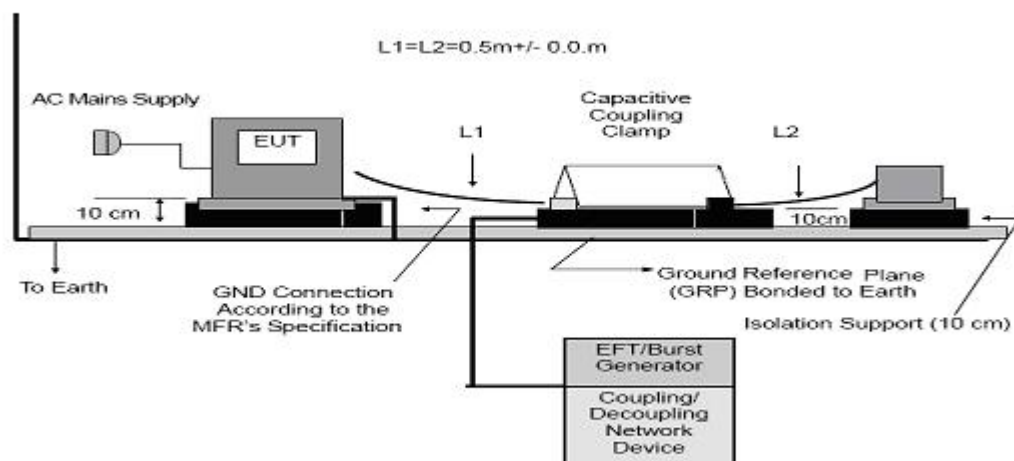
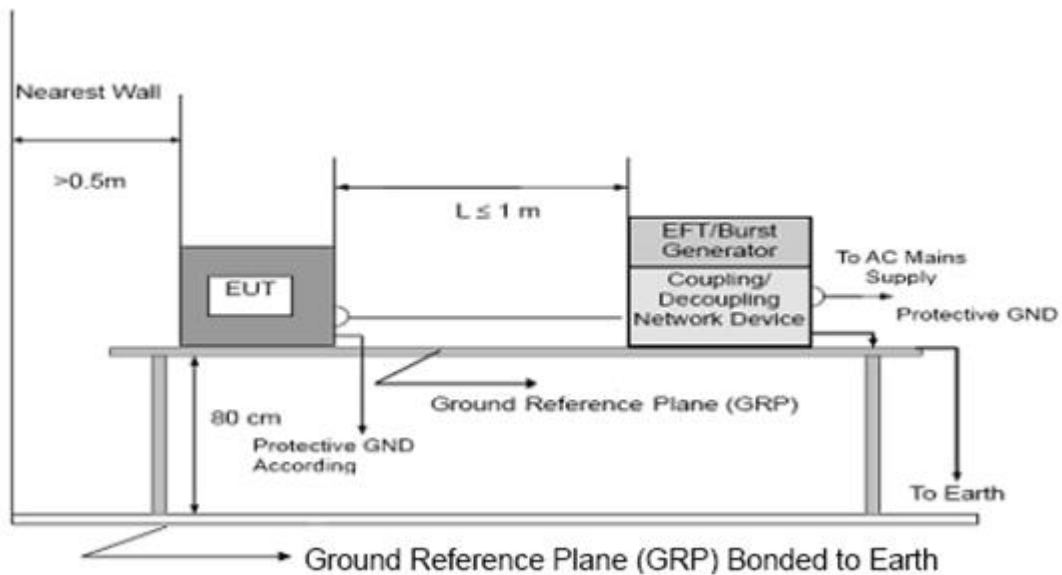

Note:

#### TABLE-TOP EQUIPMENT

The configuration consisted of a wooden table (0.8m high) standing on the Ground Reference Plane. The GRP consisted of a sheet of aluminum (at least 0.25mm thick and 2.5m square) connected to the protective grounding system. A minimum distance of 0.5m was provided between the EUT and the walls of the laboratory or any other metallic structure.

#### FLOOR-STANDING EQUIPMENT

The EUT installed in a representative system as described in section 7 of IEC/EN 61000-4-4 and its cables, were isolated from the Ground Reference Plane by an insulating support that is 0.1-meter thick. The GRP consisted of a sheet of aluminum (at least 0.25mm thick and 2.5m square) connected to the protective grounding system.

## 4.6.4 TEST RESULTS

EUT :	FINGERTEC SKADEX	Model Name :	SKADEX
Temperature :	25 °C	Relative Humidity :	60%
Pressure :	1010 hPa	Test Date :	N/A
Test Mode :	N/A		
Test Power :	N/A		

## Note:

- 1) N/A - denotes test is not applicable in this test report
- 2) There was not any unintentional transmission in standby mode

## 4.7 SURGE TESTING

### 4.7.1 TEST SPECIFICATION

Basic Standard:	IEC/EN 61000-4-5
Required Performance	B
Wave-Shape:	Combination Wave 1.2/50 us Open Circuit Voltage 8 /20 us Short Circuit Current
Test Voltage:	Power Line : 0.5 kV, 1 kV, 2 kV
Surge Input/Output:	DC Line
Generator Source:	2 ohm between networks
Impedance:	12 ohm between network and ground
Polarity:	Positive/Negative
Phase Angle:	0 /90/180/270°
Pulse Repetition Rate:	1 time / min. (maximum)
Number of Tests:	5 positive and 5 negative at selected points

### 4.7.2 TEST PROCEDURE

a. For EUT power supply:

The surge is to be applied to the EUT power supply terminals via the capacitive coupling network. Decoupling networks are required in order to avoid possible adverse effects on equipment not under test that may be powered by the same lines, and to provide sufficient decoupling impedance to the surge wave. The power cord between the EUT and the coupling/decoupling networks shall be 2meters in length (or shorter).

b. For test applied to unshielded unsymmetrically operated interconnection lines of EUT:

The surge is applied to the lines via the capacitive coupling. The coupling /decoupling networks shall not influence the specified functional conditions of the EUT. The interconnection line between the EUT and the coupling/decoupling networks shall be 2 meters in length (or shorter).

c. For test applied to unshielded symmetrically operated interconnection /telecommunication lines of EUT:

d. The surge is applied to the lines via gas arrestors coupling. Test levels below the ignition point of the coupling arrestor cannot be specified. The interconnection line between the EUT and the coupling/decoupling networks shall be 2 meters in length (or shorter).

### 4.7.3 TEST SETUP

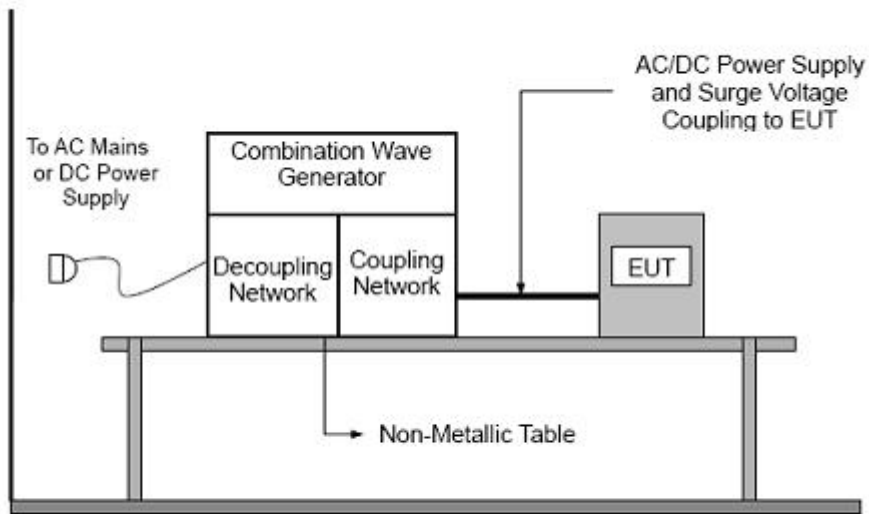



## 4.7.4 TEST RESULTS

EUT :	FINGERTEC SKADEX	Model Name :	SKADEX
Temperature :	25 °C	Relative Humidity :	60%
Pressure :	1010 hPa	Test Date :	N/A
Test Mode :	N/A		
Test Power :	N/A		

## Note:

- 1) N/A - denotes test is not applicable in this test report
- 2) There was not any unintentional transmission in standby mode

## 4.8 INJECTION CURRENT TESTING

### 4.8.1 TEST SPECIFICATION

Basic Standard:	IEC/EN 61000-4-6
Required Performance	A
Frequency Range:	0.15 MHz - 80 MHz
Field Strength:	3 Vr.m.s.
Modulation:	1kHz Sine Wave, 80%, AM Modulation
Frequency Step:	1 % of fundamental
Dwell Time:	at least 3 seconds

### 4.8.2 TEST PROCEDURE

The EUT and support equipment, are placed on a table that is 0.8 meter above a metal ground plane measured 1m\*1m min. and 0.65mm thick min.

The other condition as following manner:

- a. The frequency range is swept from 150 KHz to 80 MHz, with the signal 80%amplitude modulated with a 1kHz sine wave. The rate of sweep did not exceed  $1.5 \times 10^{-3}$  decade/s. Where the frequency range is swept incrementally, the step size was 1% of fundamental.
- b. The dwell time at each frequency shall be not less than the time necessary for the EUT to be able to respond.

## 4.8.3 TEST SETUP

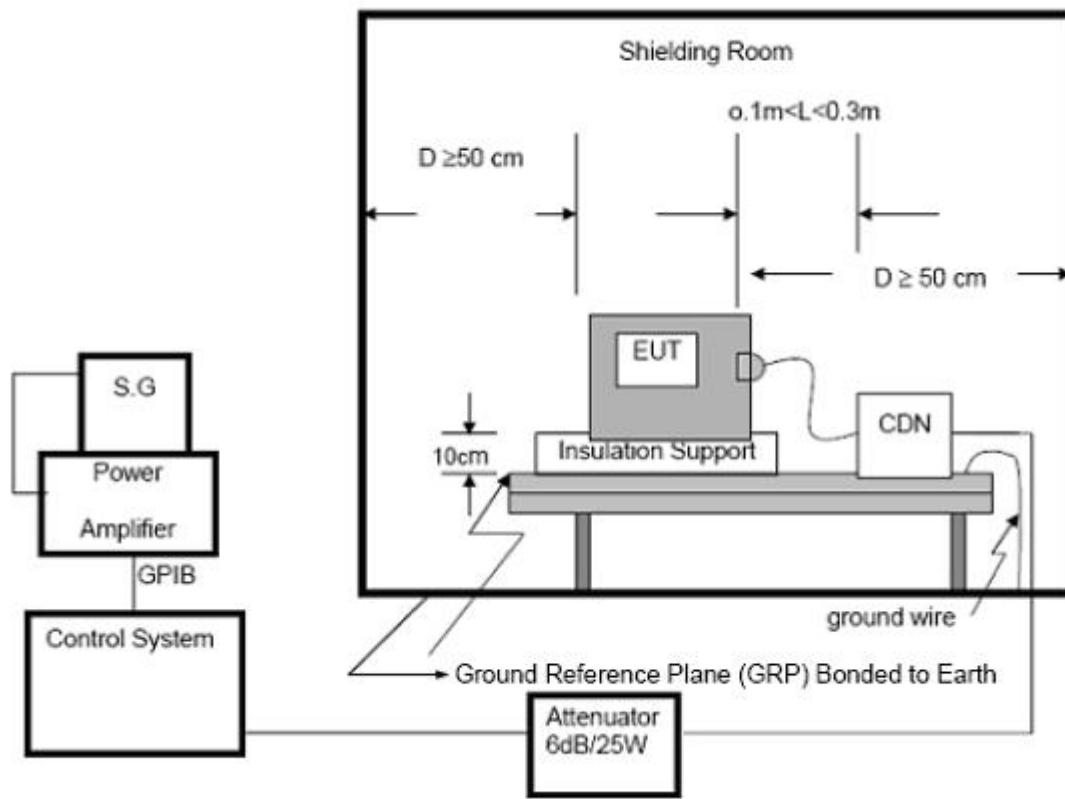

## NOTE:

## FLOOR-STANDING EQUIPMENT

The equipment to be tested is placed on an insulating support of 0.1 meters height above a ground reference plane. All relevant cables shall be provided with the appropriate coupling and decoupling devices at a distance between 0.1 meters and 0.3 meters from the projected geometry of the EUT on the ground reference plane.

## 4.8.4 TEST RESULTS

EUT :	FINGERTEC SKADEX	Model Name :	SKADEX
Temperature :	24 °C	Relative Humidity :	54%
Pressure :	1010 hPa	Test Date :	N/A
Test Mode :	N/A	Polarization :	N/A
Test Power :	N/A		

## Note:

- 1) N/A - denotes test is not applicable in this Test Report.
- 2) Criteria A: There was no change operated with initial operating during the test.
- 3) Criteria B: The EUT function loss during the test, but self-recoverable after the test.
- 4) Criteria C: The system shut down during the test.

## 4.9 VOLTAGE INTERRUPTION/DIPS TESTING

### 4.9.1 TEST SPECIFICATION

Basic Standard:	IEC/EN 61000-4-8
Required Performance	A
Frequency Range:	50Hz
Field Strength:	1 A/m
Observation Time:	1 minute
Inductance Coil:	Rectangular type, 1mx1m

### 4.9.2 TEST PROCEDURE

The EUT and support equipment, are placed on a table that is 0.8 meter above a metal ground plane measured 1m\*1m min. and 0.65mm thick min.

The other condition as following manner:

- a. The equipment cabinets shall be connected to the safety earth directly on the GRP via the earth terminal of the EUT.
- b. The cables supplied or recommended by the equipment manufacturer shall be used. 1 meter of all cables used shall be exposed to the magnetic field.

## 4.9.3 TEST SETUP

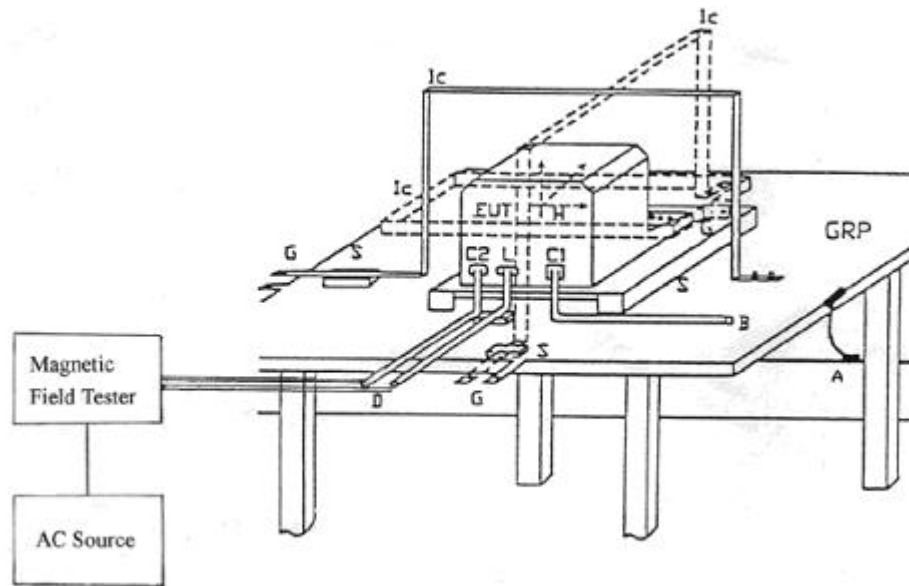

## Note:

## TABLE-TOP EQUIPMENT

The equipment shall be subjected to the test magnetic field by using the induction coil of standard dimension (1 m x 1 m). The induction coil shall then be rotated by 90 degrees in order to expose the EUT to the test field with different orientations.

## FLOOR-STANDING EQUIPMENT

The equipment shall be subjected to the test magnetic field by using induction coils of suitable dimensions. The test shall be repeated by moving and shifting the induction coils, in order to test the whole volume of the EUT for each orthogonal direction. The test shall be repeated with the coil shifted to different positions along the side of the EUT, in steps corresponding to 50 % of the shortest side of the coil. The induction coil shall then be rotated by 90 degrees in order to expose the EUT to the test field with different orientations.

## 4.9.4 TEST RESULTS

EUT :	FINGERTEC SKADEX	Model Name :	SKADEX
Temperature :	24 °C	Relative Humidity :	54%
Pressure :	1010 hPa	Test Date :	N/A
Test Mode :	N/A	Polarization :	N/A
Test Power :	N/A		

## Note:

- 1) N/A - denotes test is not applicable in this test report
- 2) Criteria A: There was no change operated with initial operating during the test.
- 3) Criteria B: The EUT function loss during the test, but self-recoverable after the test.
- 4) Criteria C: The system shut down during the test.

## 4.10 VOLTAGE INTERRUPTION/DIPS TESTING

### 4.10.1 TEST SPECIFICATION

Basic Standard:	IEC/EN 61000-4-11
Required Performance	B (For 100% Voltage Dips) C (For 30% Voltage Dips) C (For 100% Voltage Interruptions)
Test Duration Time:	Minimum three test events in sequence
Interval between Event:	Minimum ten seconds
Phase Angle:	0°/45°/90°/135°/180°/225°/270°/315°/360°
Test Cycle:	3 times

### 4.10.2 TEST PROCEDURE

The EUT shall be tested for each selected combination of test levels and duration with a sequence of three dips/interruptions with intervals of 10 s minimum (between each test event). Each representative mode of operation shall be tested. Abrupt changes in supply voltage shall occur at zero crossings of the voltage waveform.

### 4.10.3 TEST SETUP

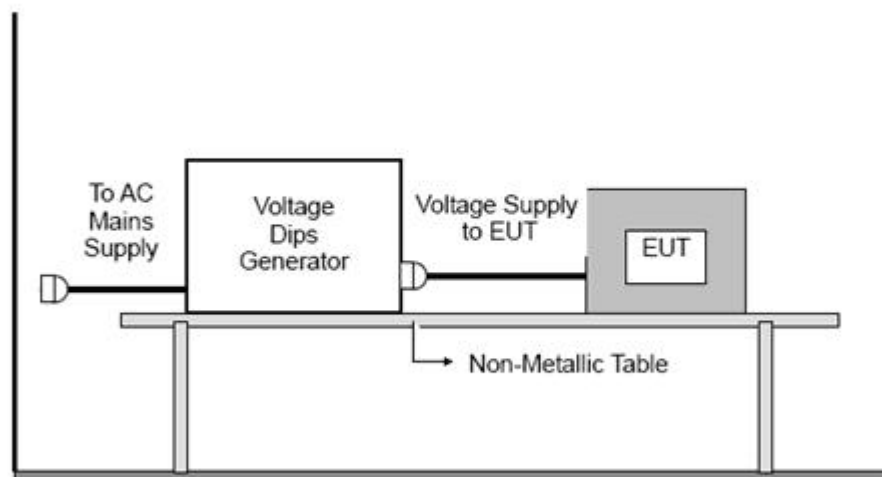



## 4.10.4 TEST RESULTS

EUT :	FINGERTEC SKADEX	Model Name :	SKADEX
Temperature :	24 °C	Relative Humidity :	54%
Pressure :	1010 hPa	Test Date :	N/A
Test Mode :	N/A	Polarization :	N/A
Test Power :	N/A		

## Note:

- 1). N/A - denotes test is not applicable in this test report.
- 2) Criteria A: There was no change operated with initial operating during the test.
- 3) Criteria B: The EUT function loss during the test, but self-recoverable after the test.
- 4) Criteria C: The system shut down during the test.

5. EUT TEST PHOTO

Radiated Measurement Photos

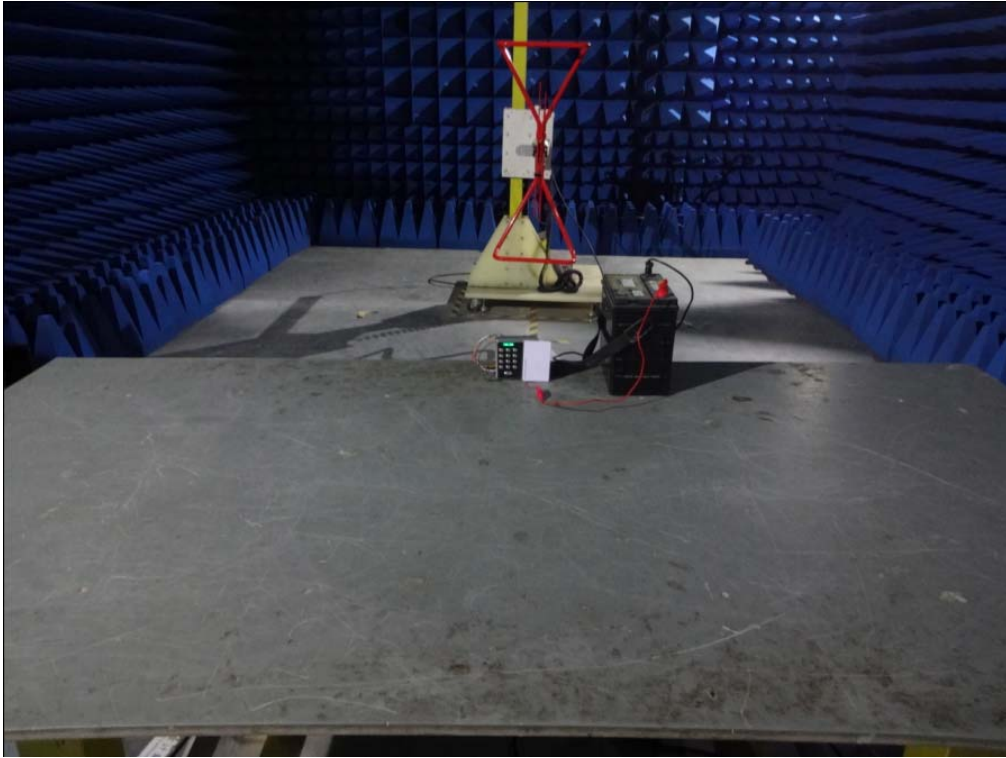

**Conducted Measurement Photos**



ATTACHMENT PHOTOGRAPHS OF EUT

Photo 1

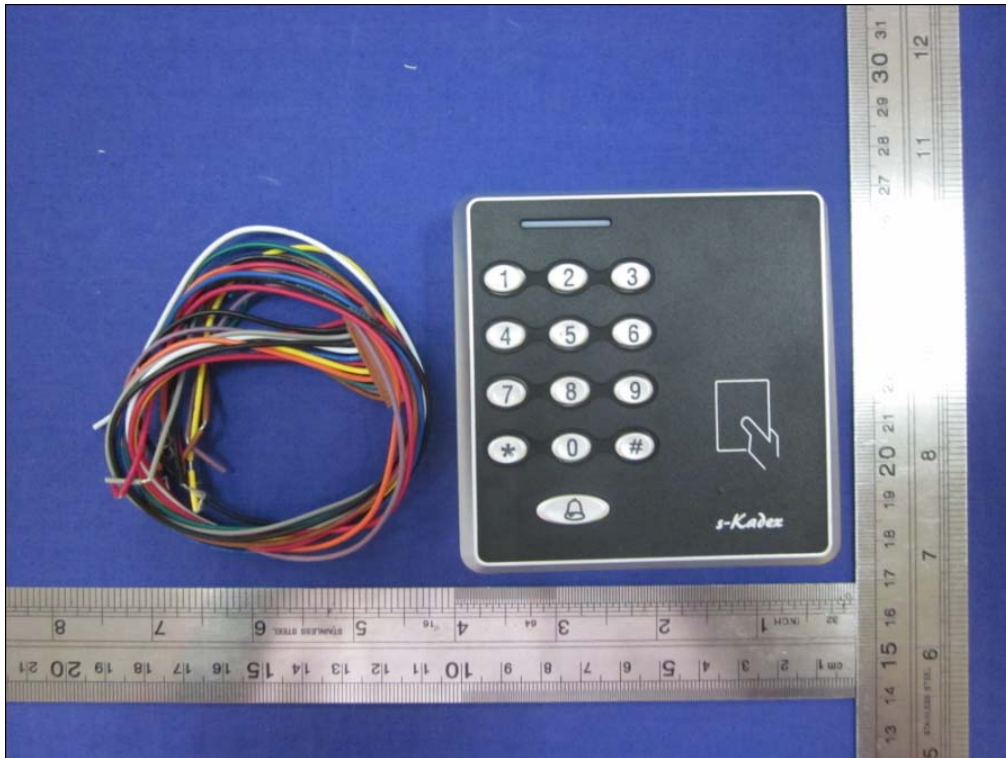

Photo 2

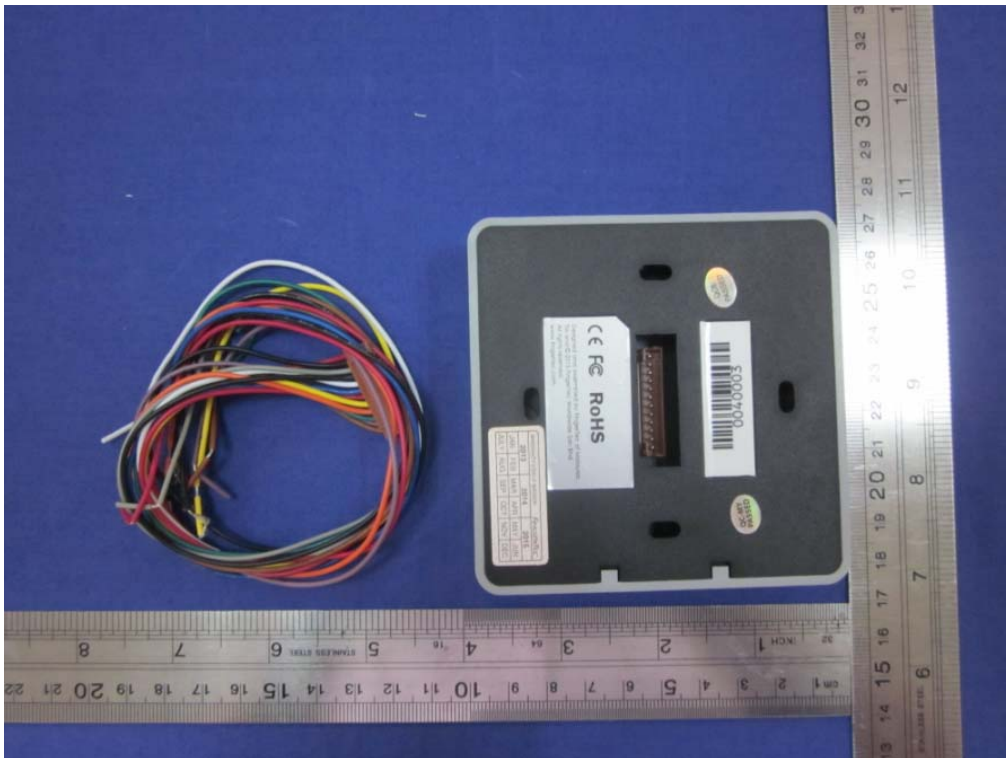

Photo 3

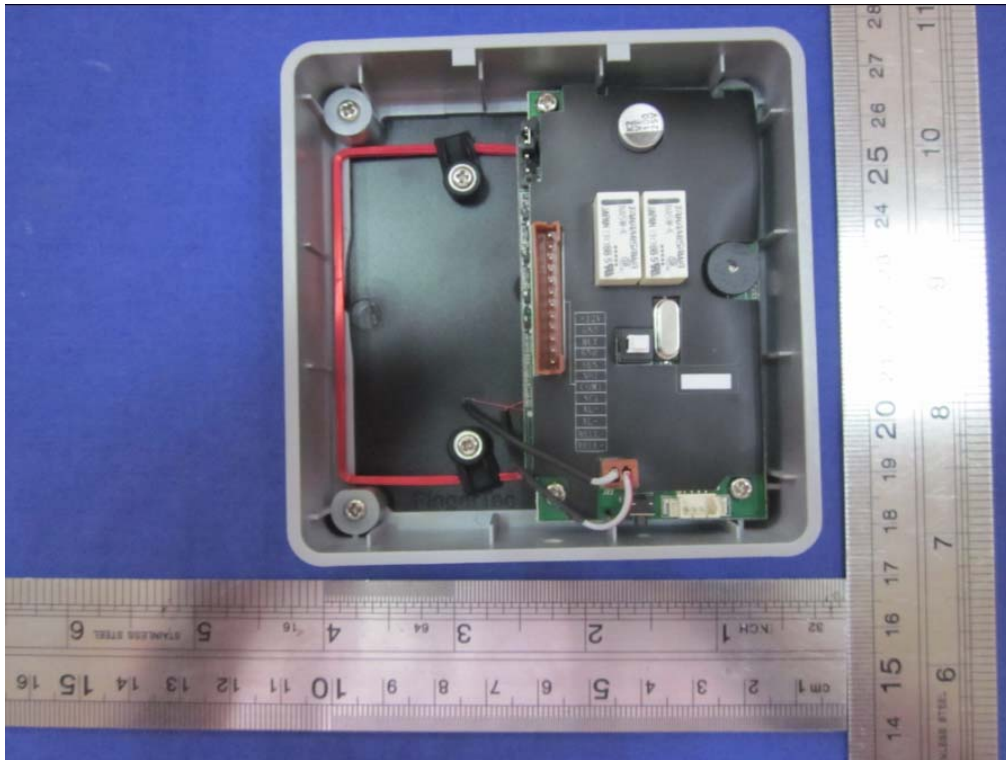

Photo 4

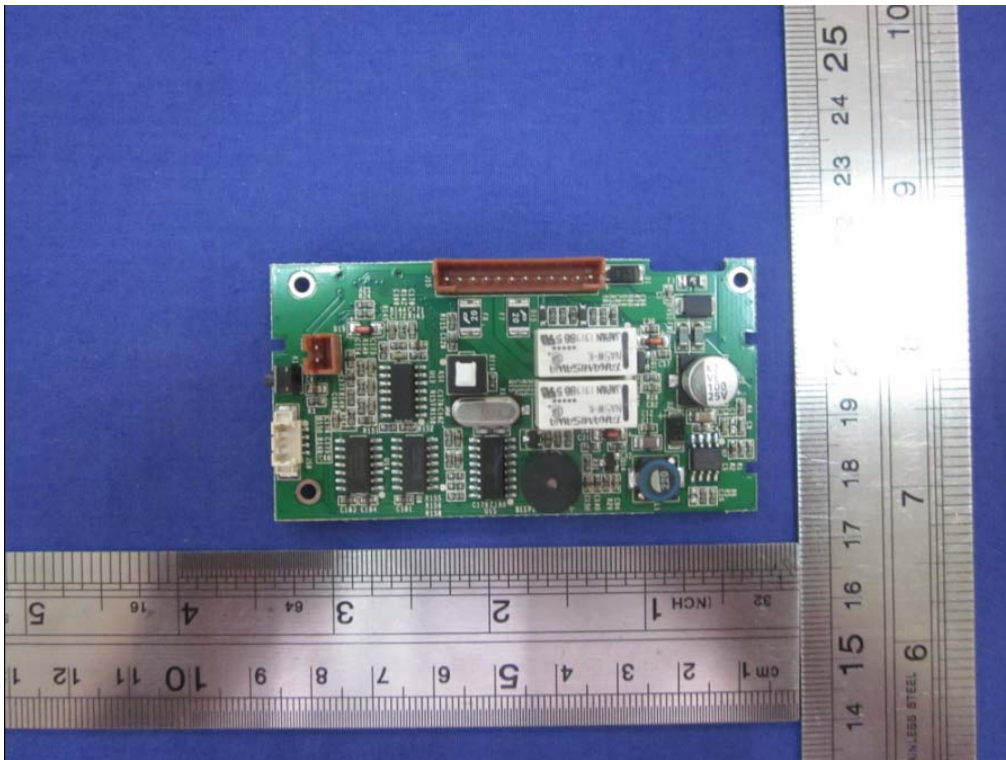



Photo 5

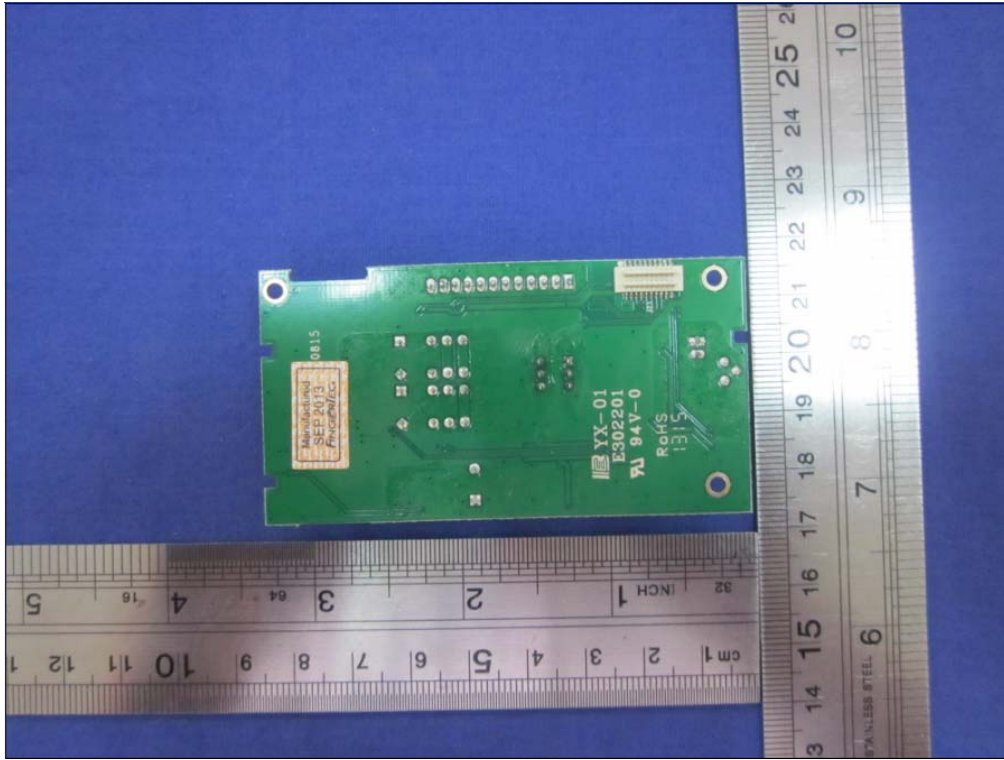

Photo 6

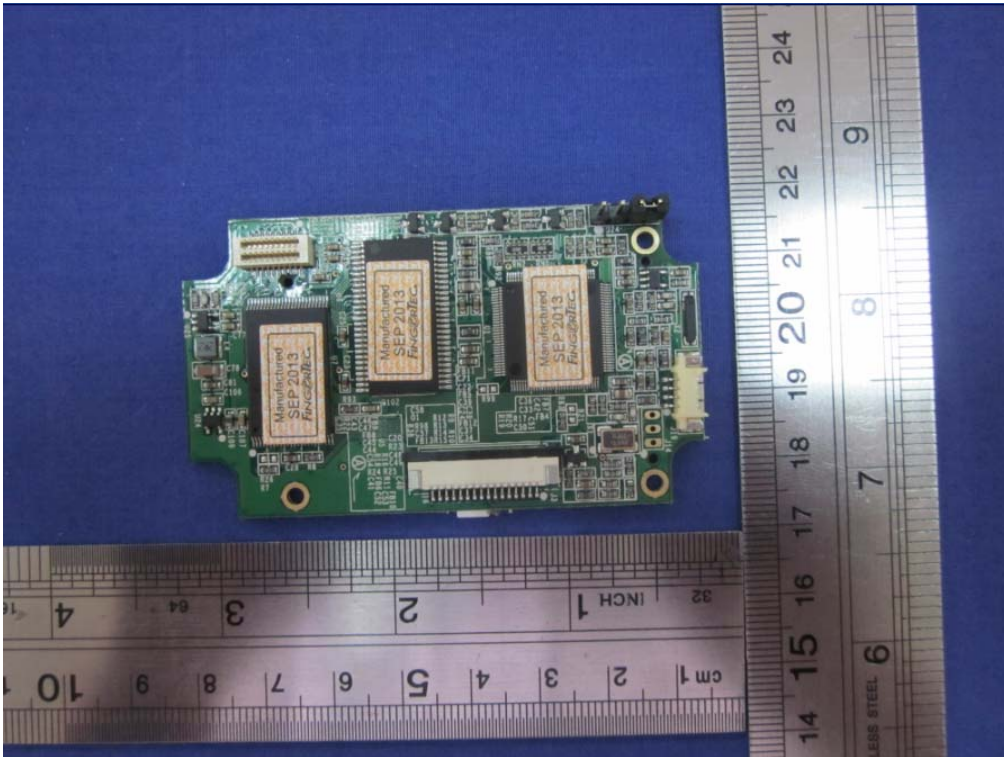

Photo 7

