

# FCC EMC Test Report



(Verification of Conformity)

For

Electromagnetic Interference

Of

**Product :** FINGERTEC INGRESSUS

**Trade Name :** FINGERTEC

**Model Number :** INGRESSUS

**Prepared for**

FINGERTEC WORLDWIDE SDN BHD.

NO. 6, 8 & 10 JALAN BK 3/2 BANDAR KINRARA, 47180 PUCHONG, SELANGOR.

**Prepared by**

WST Certification & Testing (HK) Limited

12/F., San Toi Building, 137-139 Connaught Road Central, Hong Kong

Tel: (00852) -21393077 Fax: (00852) -21393217  
Shenzhen office: Tel:0755-27822785 Fax:0755-27822175  
Website: [Http:// www.wstlab.com](http://www.wstlab.com)

### TEST RESULT CERTIFICATION

**Applicant's name** ..... : FINGERTEC WORLDWIDE SDN BHD.  
**Address** ..... : NO. 6, 8 & 10 JALAN BK 3/2 BANDAR KINRARA, 47180  
 PUCHONG, SELANGOR.  
**Manufacturer's Name** ..... : FINGERTEC WORLDWIDE SDN BHD.  
**Address** ..... : NO. 6, 8 & 10 JALAN BK 3/2 BANDAR KINRARA, 47180  
 PUCHONG, SELANGOR.

**Product description**

**Product name** ..... : FINGERTEC INGRESSUS  
**Trade Mark**..... : FINGERTEC  
**Model and/or type reference** : INGRESSUS

**Standards** ..... : FCC Part 15 Subpart B  
 ANSI C63.4:2009

This device described above has been tested by WST, and the test results show that the equipment under test (EUT) is in compliance with Part 15 of FCC Rules. And it is applicable only to the tested sample identified in the report.

This report shall not be reproduced except in full, without the written approval of WST, this document may be altered or revised by WST, personal only, and shall be noted in the revision of the document.

**Date of Test** ..... :  
**Date (s) of performance of tests** ..... : Sep. 09, 2013 ~ Sep. 17, 2013  
**Date of Issue** ..... : Sep. 17, 2013  
**Test Result**..... : **Pass**

Testing Engineer : Eric Xie  
 (Eric Xie)

Technical Manager : Nico Lee  
 (Nico Lee)

Authorized Signatory : Michael Ling  
 (Michael Ling)

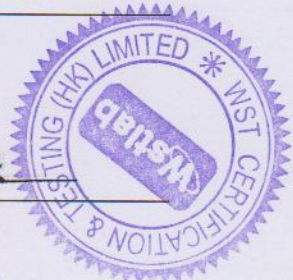

1 . TEST SUMMARY	4
1.1 TEST FACILITY	5
1.2 MEASUREMENT UNCERTAINTY	5
2 . GENERAL INFORMATION	6
2.1 GENERAL DESCRIPTION OF EUT	6
2.2 DESCRIPTION OF TEST MODES	7
2.3 DESCRIPTION OF TEST SETUP	8
2.4 DESCRIPTION TEST PERIPHERAL AND EUT PERIPHERAL	9
2.5 MEASUREMENT INSTRUMENTS LIST	10
3 . EMC EMISSION TEST	11
3.1 CONDUCTED EMISSION MEASUREMENT	11
3.1.1 POWER LINE CONDUCTED EMISSION	11
3.1.2 TEST PROCEDURE	12
3.1.3 TEST SETUP	12
3.1.4 EUT OPERATING CONDITIONS	12
3.1.5 TEST RESULTS	13
3.2 RADIATED EMISSION MEASUREMENT	15
3.2.1 LIMITS OF RADIATED EMISSION MEASUREMENT	15
3.2.2 TEST PROCEDURE	15
3.2.3 TEST SETUP	16
3.2.4 EUT OPERATING CONDITIONS	16
3.2.5 TEST RESULTS	17
3.2.6 TEST RESULTS(Above 1GHz)	19
4 . EUT TEST PHOTO	20
ATTACHMENT PHOTOGRAPHS OF EUT	22

## 1. TEST SUMMARY

Test procedures according to the technical standards:

EMC Emission				
Standard	Test Item	Limit	Judgment	Remark
FCC Part 15 Subpart B ANSI C63.4:2009	Conducted Emission	Class B	PASS	
	Radiated Emission	Class B	PASS	

**NOTE:**

- (1) 'N/A' denotes test is not applicable in this Test Report
- (2) For client's request and manual description, the test will not be executed.

1.1 TEST FACILITY

WST Certification & Testing (HK) Limited

Add. : 12/F., San Toi Building, 137-139 Connaught Road Central, Hong Kong

1.2 MEASUREMENT UNCERTAINTY

The reported uncertainty of measurement  $y \pm U$ , where expanded uncertainty  $U$  is based on a standard uncertainty multiplied by a coverage factor of  $k=2$ , providing a level of confidence of approximately **95 %**.

A. Conducted Measurement :

Test Site	Method	Measurement Frequency Range	U , (dB)	NOTE
WSTC01	ANSI	150 KHz ~ 30MHz	3.2	

B. Radiated Measurement :

Test Site	Method	Measurement Frequency Range	U , (dB)	NOTE
WSTA01	ANSI	30MHz ~ 1000MHz	4.7	

## 2. GENERAL INFORMATION

### 2.1 GENERAL DESCRIPTION OF EUT

Equipment	FINGERTEC INGRESSUS	
Model Name	INGRESSUS	
Serial No	N/A	
Model Difference	N/A	
Product Description	The EUT is a FINGERTEC INGRESSUS	
	Operating frequency:	N/A
	Connecting I/O port:	N/A
	Based on the application, features, or specification exhibited in User's Manual, the EUT is considered as an ITE/Computing Device. More details of EUT technical specification, please refer to the User's Manual.	
Power Source	DC Voltage	
Power Rating	DC 12V, 3A	

## 2.2 DESCRIPTION OF TEST MODES

To investigate the maximum EMI emission characteristics generated from EUT, the test system was pre-scanning tested based on the consideration of following EUT operation mode or test configuration mode which possibly have effect on EMI emission level. Each of these EUT operation mode(s) or test configuration mode(s) mentioned above was evaluated respectively.

Pretest Mode	Description
Mode 1	Running

For Conducted Test	
Final Test Mode	Description
Mode 1	Running

For Radiated Test	
Final Test Mode	Description
Mode 1	Running

### 2.3 DESCRIPTION OF TEST SETUP

Mode 1:

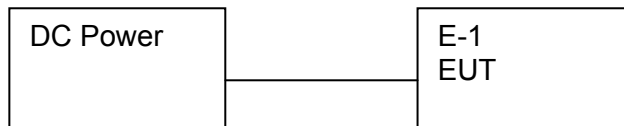



## 2.4 DESCRIPTION TEST PERIPHERAL AND EUT PERIPHERAL

The EUT has been tested as an independent unit together with other necessary accessories or support units. The following support units or accessories were used to form a representative test configuration during the tests.

Item	Equipment	Mfr/Brand	Model/Type No.	Series No.	Note
E-1	FINGERTEC INGRESSUS	FINGERTEC C	INGRESSUS	N/A	EUT

Item	Shielded Type	Ferrite Core	Length	Note

**Note:**

- (1) The support equipment was authorized by Declaration of Confirmation.
- (2) For detachable type I/O cable should be specified the length in cm in 『Length』 column.
- (3) “YES” is means “shielded” “with core”; “NO” is means “unshielded” “without core”.

## 2.5 MEASUREMENT INSTRUMENTS LIST

### 2.5.1 CONDUCTED TEST SITE

Item	Kind of Equipment	Manufacturer	Type No.	Serial No.	Calibrated until
1	LISN	R&S	ENV216	101313	Jul. 06, 2014
2	LISN	EMCO	3816/2	00042990	Jul. 06, 2014
3	50Ω Switch	ANRITSU CORP	MP59B	6200983704	Jul. 06, 2014
4	Test Cable	N/A	C01	N/A	Jul. 06, 2014
5	Test Cable	N/A	C02	N/A	Jul. 06, 2014
6	Test Cable	N/A	C03	N/A	Jul. 06, 2014
7	EMI Test Receiver	R&S	ESCI	101160	Jul. 06, 2014
8	Passive Voltage Probe	ESH2-Z3	R&S	100196	Jul. 06, 2014
9	Triple-Loop Antenna	EVERFINE	LIA-2	11020003	Jul. 06, 2014
10	Absorbing Clamp	R&S	MDS-21	100423	Jul. 08, 2014

### 2.5.2 RADIATED TEST SITE

Item	Kind of Equipment	Manufacturer	Type No.	Serial No.	Calibrated until
1	Bilog Antenna	TESEQ	CBL6111D	31216	Jul. 06, 2014
2	Test Cable	N/A	R-01	N/A	Jul. 06, 2014
3	Test Cable	N/A	R-02	N/A	Jul. 06, 2014
4	EMI Test Receiver	R&S	ESCI-7	101318	Jul. 06, 2014
5	Antenna Mast	EM	SC100_1	N/A	N/A
6	Turn Table	EM	SC100	060531	N/A
7	50Ω Switch	Anritsu Corp	MP59B	6200983705	Jul. 06, 2014
8	Spectrum Analyzer	Aglient	E4407B	MY45108040	Jul. 06, 2014
9	Horn Antenna	EM	EM-AH-1018 0	2011071402	Jul. 06, 2014
10	Amplifier	EM	EM-30180	060538	Jul. 06, 2014

### 3. EMC EMISSION TEST

#### 3.1 CONDUCTED EMISSION MEASUREMENT

##### 3.1.1 POWER LINE CONDUCTED EMISSION (Frequency Range 150KHz-30MHz)

FREQUENCY (MHz)	Class A (dBuV)		Class B (dBuV)	
	Quasi-peak	Average	Quasi-peak	Average
0.15 -0.5	79.00	66.00	66 - 56 *	56 - 46 *
0.50 -5.0	73.00	60.00	56.00	46.00
5.0 -30.0	73.00	60.00	60.00	50.00

Note:

- (1) The tighter limit applies at the band edges.
- (2) The limit of " \* " marked band means the limitation decreases linearly with the logarithm of the frequency in the range.

The following table is the setting of the receiver

Receiver Parameters	Setting
Attenuation	10 dB
Start Frequency	0.15 MHz
Stop Frequency	30 MHz
IF Bandwidth	9 kHz

### 3.1.2 TEST PROCEDURE

- a. The EUT was placed 0.4 meters from the horizontal ground plane with EUT being connected to the power mains through a line impedance stabilization network (LISN). All other support equipments powered from additional LISN(s). The LISN provide 50 Ohm/ 50uH of coupling impedance for the measuring instrument.
- b. Interconnecting cables that hang closer than 40 cm to the ground plane shall be folded back and forth in the center forming a bundle 30 to 40 cm long.
- c. I/O cables that are not connected to a peripheral shall be bundled in the center. The end of the cable may be terminated, if required, using the correct terminating impedance. The overall length shall not exceed 1 m.
- d. LISN at least 80 cm from nearest part of EUT chassis.
- e. For the actual test configuration, please refer to the related Item –EUT Test Photos.

### 3.1.3 TEST SETUP

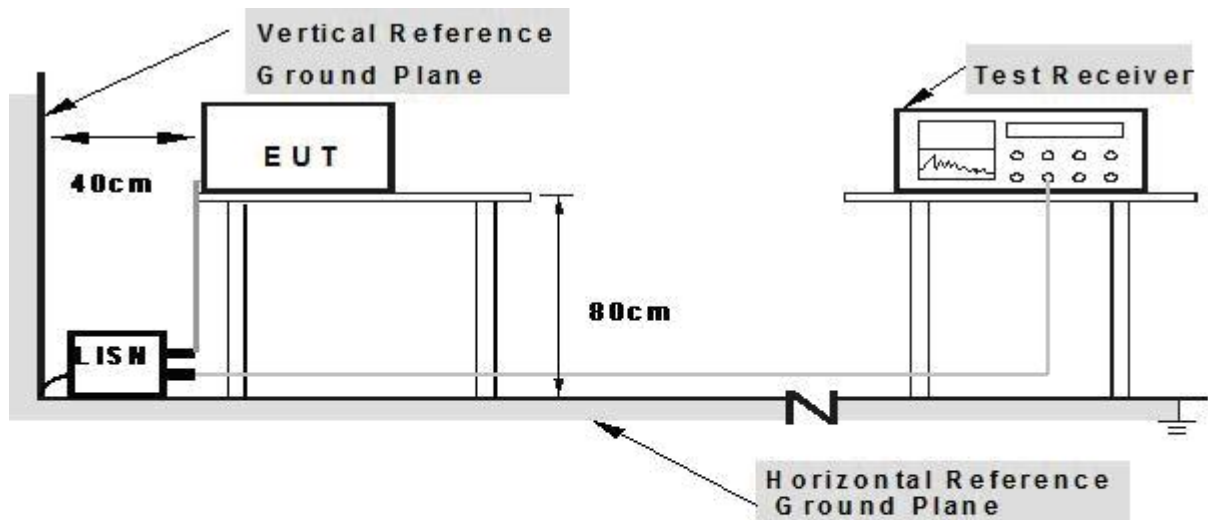

**Note: 1. Support units were connected to second LISN.**

**2. Both of LISNs (AMN) are 80 cm from EUT and at least 80 cm from other units and other metal planes**

### 3.1.4 EUT OPERATING CONDITIONS

The EUT tested system was configured as the statements of 2.3 Unless otherwise a special operating condition is specified in the follows during the testing.

### 3.1.5 TEST RESULTS

EUT :	FINGERTEC INGRESSUS	Model Name. :	INGRESSUS
Temperature :	26 °C	Relative Humidity :	54%
Pressure :	1010hPa	Test Date :	2013-09-13
Test Mode :	Running	Phase :	L
Test Voltage :	DC 12V, 3A		

No. Mk.	Freq. MHz	Reading Level dBuV	Correct Factor dB	Measure- ment dBuV	Limit dBuV	Over dB	Detector	Comment
1	0.5740	30.88	10.62	41.50	56.00	-14.50	QP	
2 *	0.5740	26.85	10.62	37.47	46.00	-8.53	AVG	
3	1.1460	28.40	10.74	39.14	56.00	-16.86	QP	
4	1.1460	25.41	10.74	36.15	46.00	-9.85	AVG	
5	1.7260	28.09	10.72	38.81	56.00	-17.19	QP	
6	1.7260	25.57	10.72	36.29	46.00	-9.71	AVG	
7	2.2940	25.91	10.70	36.61	56.00	-19.39	QP	
8	2.2940	23.61	10.70	34.31	46.00	-11.69	AVG	
9	2.8699	25.29	10.68	35.97	56.00	-20.03	QP	
10	2.8699	15.34	10.68	26.02	46.00	-19.98	AVG	
11	3.4460	24.61	10.66	35.27	56.00	-20.73	QP	
12	3.4460	19.81	10.66	30.47	46.00	-15.53	AVG	

**Remark:**

1. All readings are Quasi-Peak and Average values.
2. Factor = Antenna Factor + Cable Loss.
3. N/A means All Data have pass Limit

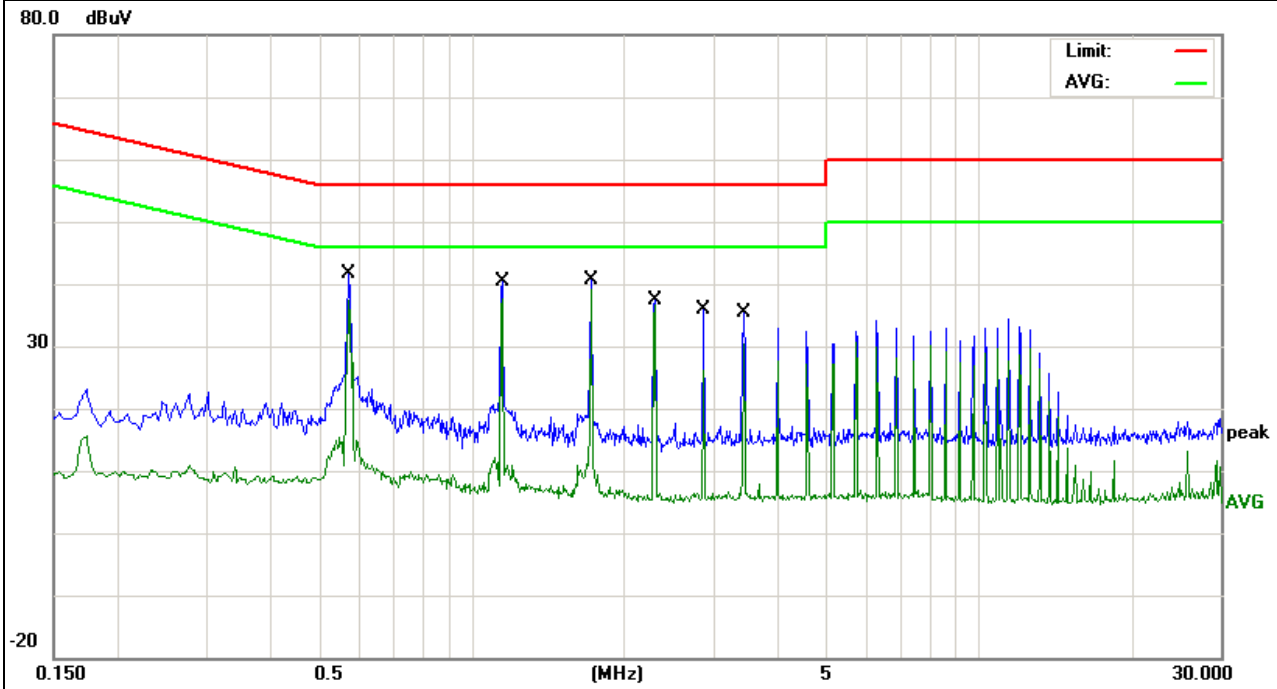

EUT :	FINGERTEC INGRESSUS	Model Name. :	INGRESSUS
Temperature :	26 °C	Relative Humidity :	54%
Pressure :	1010hPa	Test Date :	2013-09-13
Test Mode :	Running	Phase :	N
Test Voltage :	DC 12V, 3A		

No.	Mk.	Freq. MHz	Reading Level dBuV	Correct Factor dB	Measure- ment dBuV	Limit dBuV	Over dB	Detector	Comment
1		0.5740	33.32	10.62	43.94	56.00	-12.06	QP	
2	*	0.5740	29.39	10.62	40.01	46.00	-5.99	AVG	
3		1.1460	29.07	10.74	39.81	56.00	-16.19	QP	
4		1.1460	26.07	10.74	36.81	46.00	-9.19	AVG	
5		1.7260	28.26	10.72	38.98	56.00	-17.02	QP	
6		1.7260	26.96	10.72	37.68	46.00	-8.32	AVG	
7		2.2980	26.95	10.70	37.65	56.00	-18.35	QP	
8		2.2980	25.63	10.70	36.33	46.00	-9.67	AVG	
9		3.4460	23.12	10.66	33.78	56.00	-22.22	QP	
10		3.4460	19.42	10.66	30.08	46.00	-15.92	AVG	
11		11.4819	24.67	10.41	35.08	60.00	-24.92	QP	
12		11.4819	20.76	10.41	31.17	50.00	-18.83	AVG	

**Remark:**

1. All readings are Quasi-Peak and Average values.
2. Factor = Antenna Factor + Cable Loss.
3. N/A means All Data have pass Limit

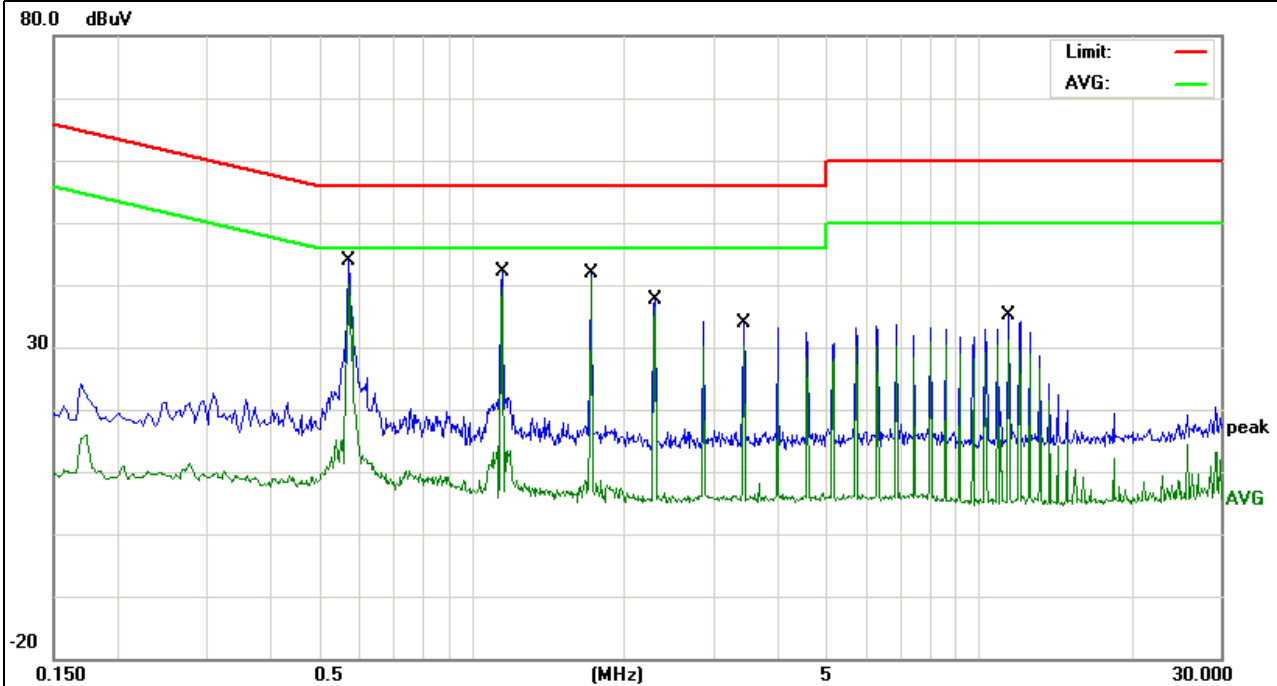

### 3.2 RADIATED EMISSION MEASUREMENT

#### 3.2.1 LIMITS OF RADIATED EMISSION MEASUREMENT

FREQUENCY (MHz)	Class A (at 10m)	Class B (at 3m)
	dBuV/m	dBuV/m
30 ~ 88	39.0	40.0
88 ~ 216	43.5	43.5
216 ~ 960	46.5	46.0
Above 960	49.5	54.0

Notes:

- (1) The limit for radiated test was performed according to as following:  
 FCC PART 15B /ICES-003.
- (2) The tighter limit applies at the band edges.
- (3) Emission level (dBuV/m)=20log Emission level (uV/m).

#### 3.2.2 TEST PROCEDURE

- a. The measuring distance of at 10 m shall be used for measurements at frequency up to 1GHz. For frequencies above 1GHz, any suitable measuring distance may be used.
- b. The EUT was placed on the top of a rotating table 0.8 meters above the ground at a 10 meter open area test site. The table was rotated 360 degrees to determine the position of the highest radiation.
- c. The height of the equipment or of the substitution antenna shall be 0.8 m; the height of the test antenna shall vary between 1 m to 4 m. Both horizontal and vertical polarizations of the antenna are set to make the measurement.
- d. The initial step in collecting conducted emission data is a spectrum analyzer peak detector mode pre-scanning the measurement frequency range. Significant peaks are then marked and then Quasi Peak detector mode re-measured, above 1G Average detector mode will be instead.
- e. If the Peak Mode measured value compliance with and lower than Quasi Peak Mode Limit, the EUT shall be deemed to meet QP(AV) Limits and then no additional QP Mode measurement performed.
- f. For the actual test configuration, please refer to the related Item –EUT Test Photos.

### 3.2.3 TEST SETUP

#### (A) Radiated Emission Test Set-Up Frequency Below 1 GHz

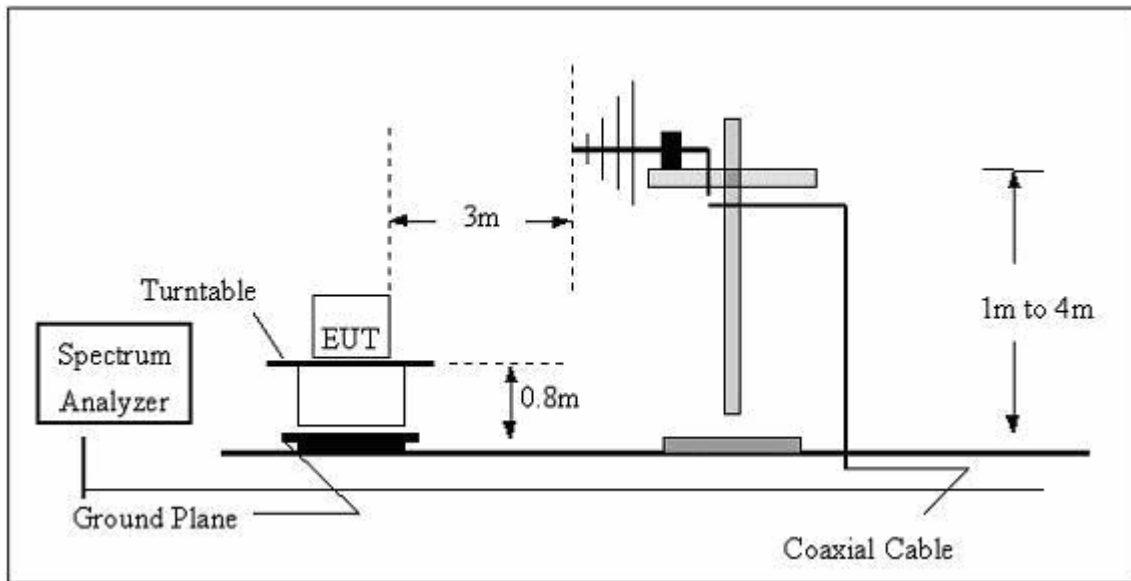

#### (B) Radiated Emission Test Set-Up Frequency Above 1GHz

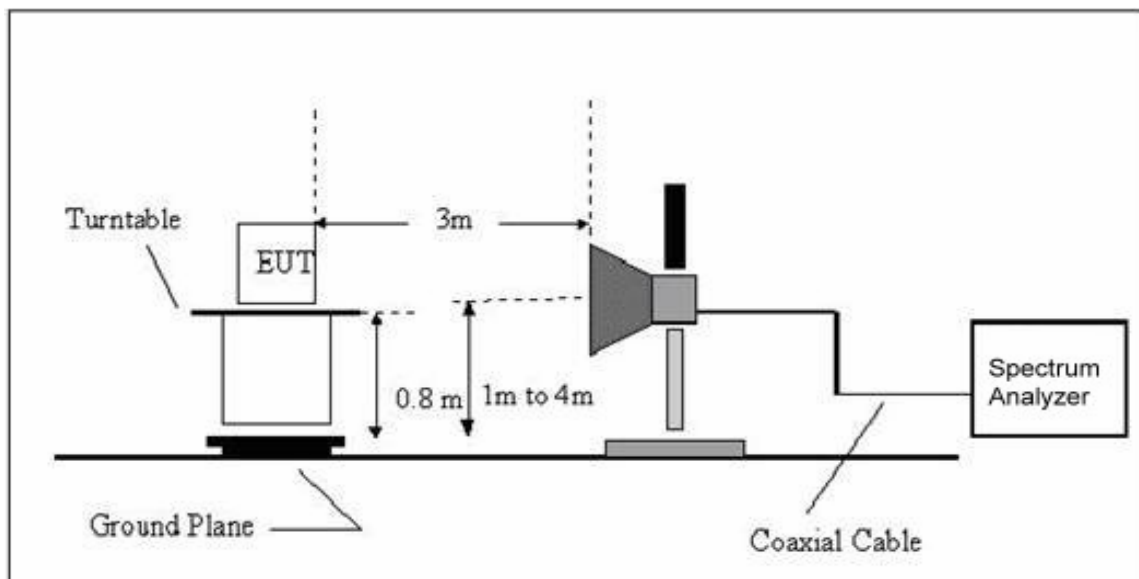

### 3.2.4 EUT OPERATING CONDITIONS

The EUT tested system was configured as the statements of 2.3 Unless otherwise a special operating condition is specified in the follows during the testing.



### 3.2.5 TEST RESULTS

EUT :	FINGERTEC INGRESSUS	Model Name :	INGRESSUS
Temperature :	24 °C	Relative Humidity :	54%
Pressure :	1010 hPa	Test Date :	2013-09-13
Test Mode :	Running	Polarization :	Horizontal
Test Power :	DC 12V, 3A		

No.	Mk.	Freq. MHz	Reading Level dBuV	Correct Factor dB	Measure- ment dBuV/m	Limit dBuV/m	Over dB	Antenna Height cm	Table Degree degree	Comment
1		86.2001	33.97	-9.67	24.30	40.00	-15.70	QP		
2	*	195.1365	39.68	-6.50	33.18	43.50	-10.32	QP		
3		336.0352	39.02	-4.00	35.02	46.00	-10.98	QP		
4		560.6928	27.21	2.85	30.06	46.00	-15.94	QP		
5		672.8444	28.79	4.46	33.25	46.00	-12.75	QP		
6		785.0935	28.17	4.94	33.11	46.00	-12.89	QP		

**Remark:**

1. All readings are Quasi-Peak and Average values.
2. Factor = Antenna Factor + Cable Loss.
3. N/A means All Data have pass Limit

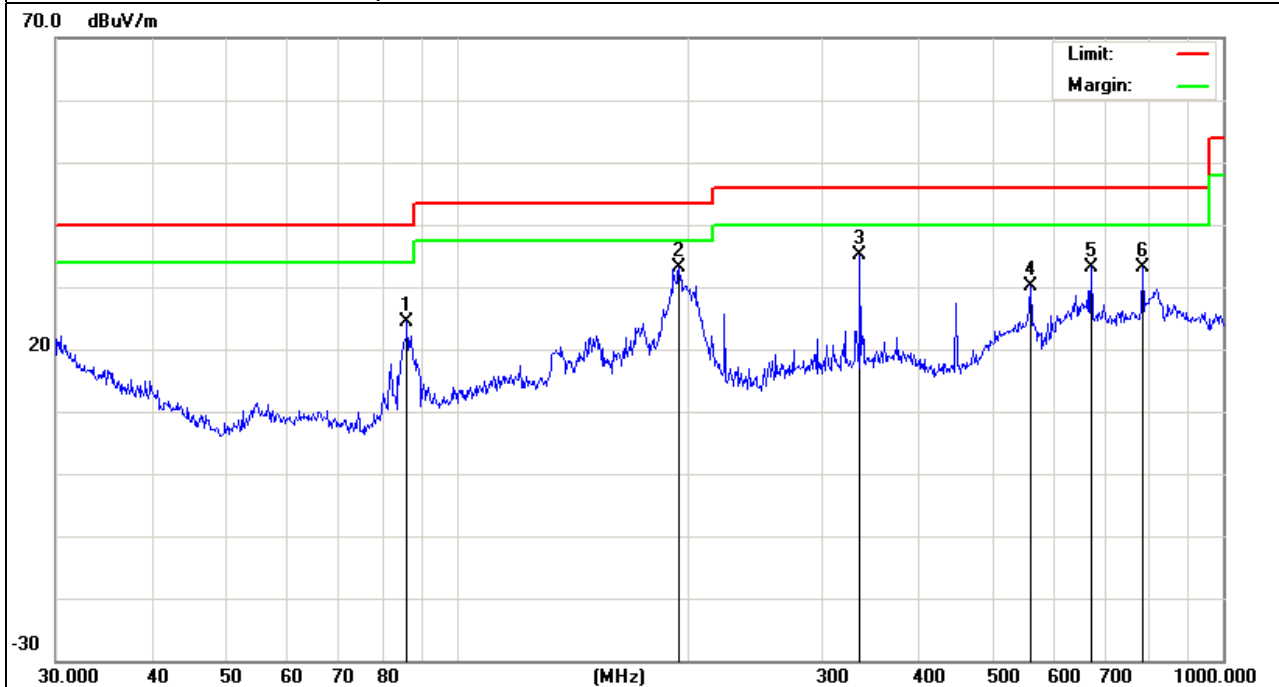

EUT :	FINGERTEC INGRESSUS	Model Name :	INGRESSUS
Temperature :	24 °C	Relative Humidity :	54%
Pressure :	1010 hPa	Test Date :	2013-09-13
Test Mode :	Running	Polarization :	Vertical
Test Power :	DC 12V, 3A		

No.	Mk.	Freq. MHz	Reading Level dBuV	Correct Factor dB	Measure- ment dBuV/m	Limit dBuV/m	Over dB	Antenna Height cm	Table Degree degree	Comment
1		87.1117	28.71	-10.61	18.10	40.00	-21.90	QP		
2		111.7380	26.36	-5.46	20.90	43.50	-22.60	QP		
3		192.4186	26.83	-4.70	22.13	43.50	-21.37	QP		
4	*	336.0352	40.24	-3.20	37.04	46.00	-8.96	QP		
5		560.6928	27.38	1.88	29.26	46.00	-16.74	QP		
6		785.0935	25.86	4.39	30.25	46.00	-15.75	QP		

Remark:

1. All readings are Quasi-Peak and Average values.
2. Factor = Antenna Factor + Cable Loss.
3. N/A means All Data have pass Limit

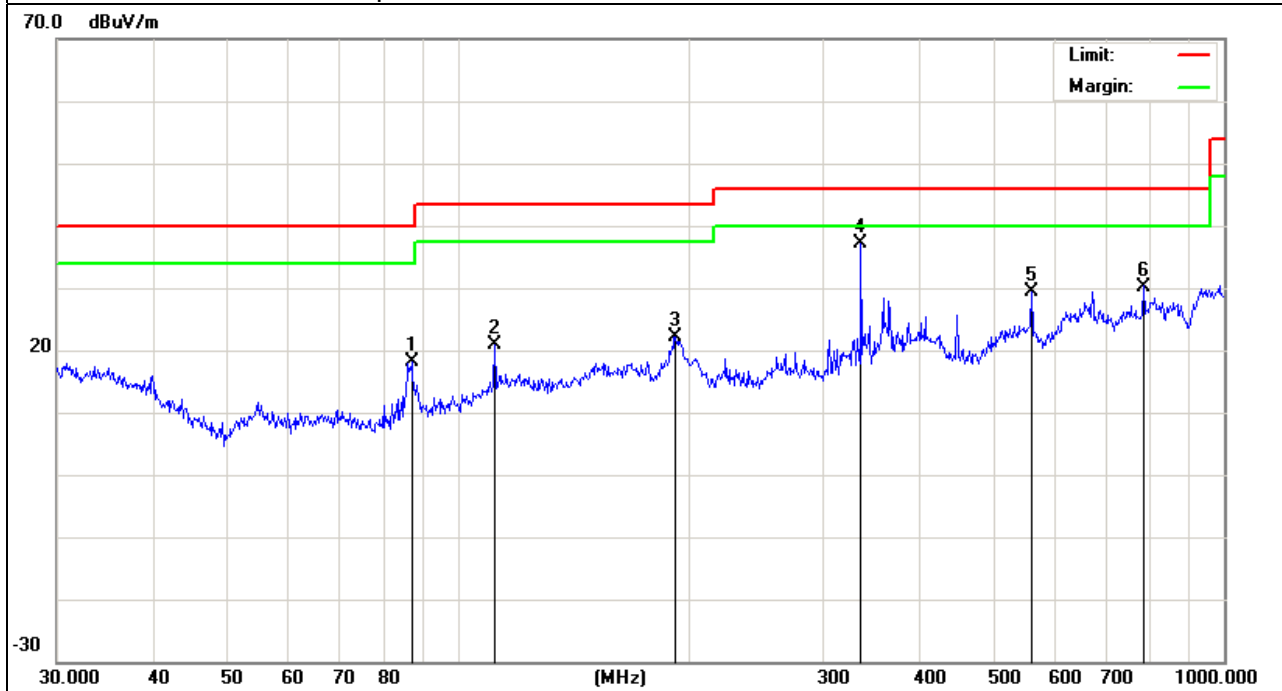

## 3.2.6 TEST RESULTS(Above 1GHz)

EUT :	FINGERTEC INGRESSUS	Model Name :	INGRESSUS
Temperature :	24 °C	Relative Humidity :	54%
Pressure :	1010 hPa	Test Date :	N/A
Test Mode :	N/A		
Test Power :	N/A		

## Note:

- 1) N/A - denotes test is not applicable in this test report
- 2) There was not any unintentional transmission in standby mode

#### 4. EUT TEST PHOTO

**Radiated Measurement Photos**

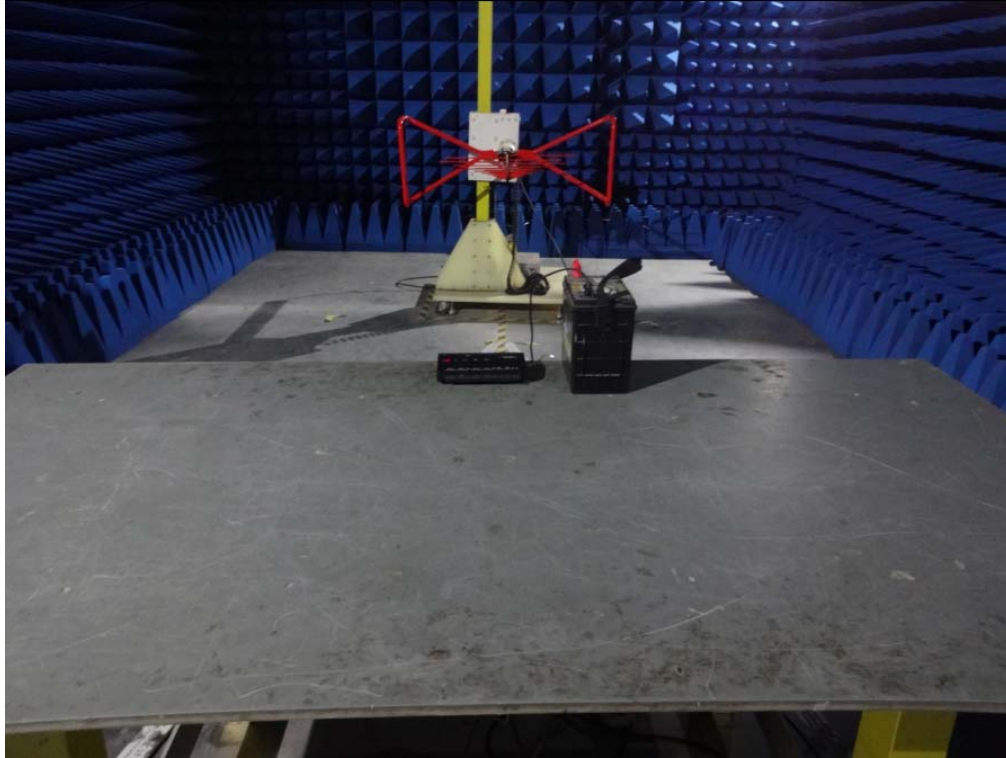

**Conducted Measurement Photos**



ATTACHMENT PHOTOGRAPHS OF EUT

Photo 1

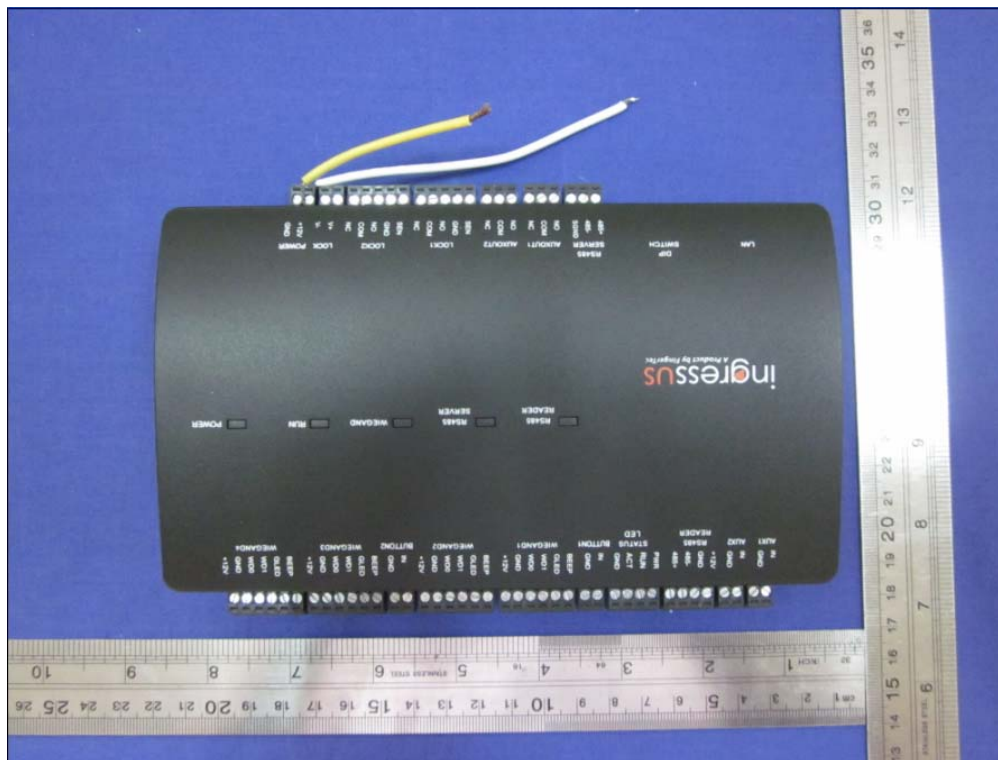

Photo 2

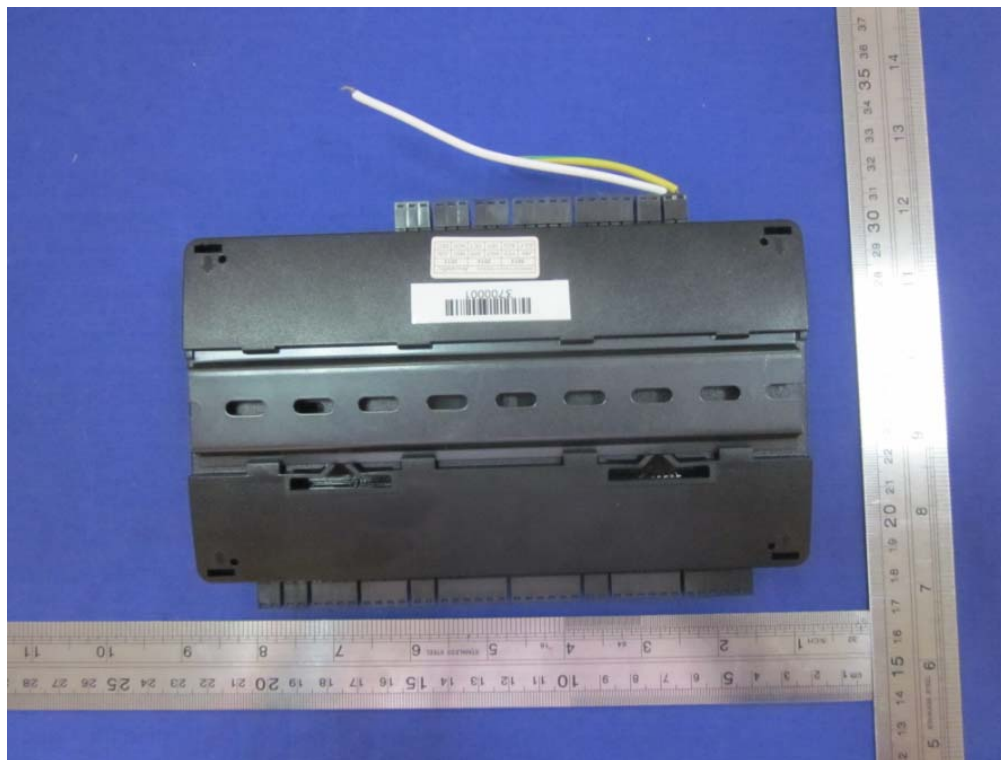

Photo 3

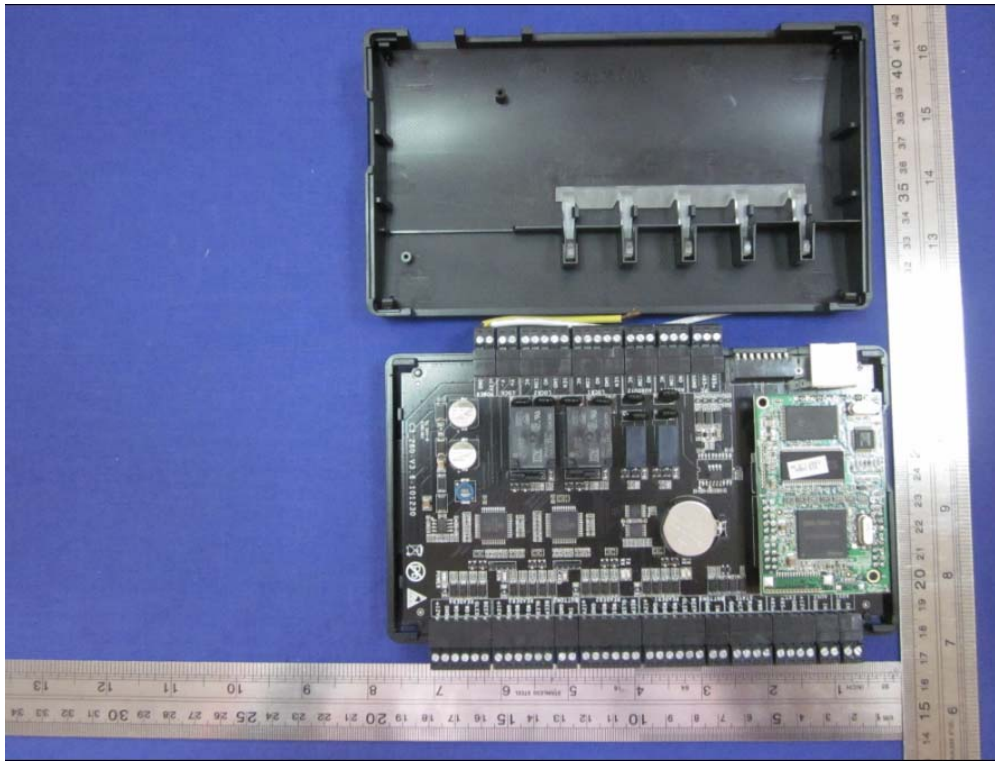

Photo 4

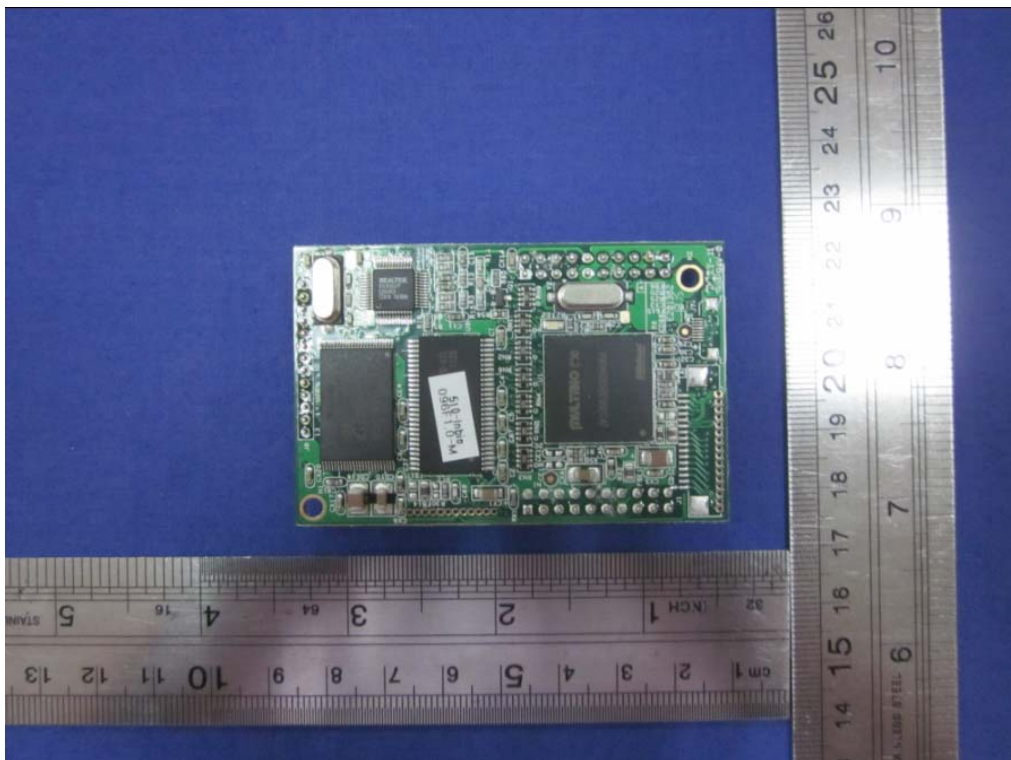

Photo 5

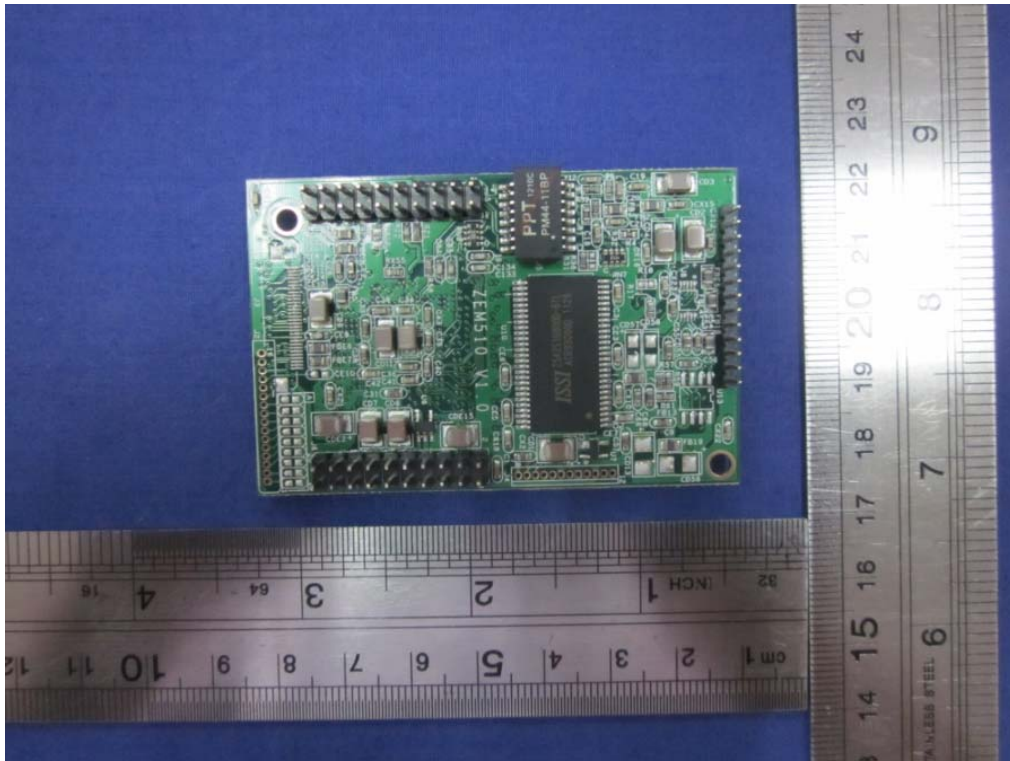

Photo 6

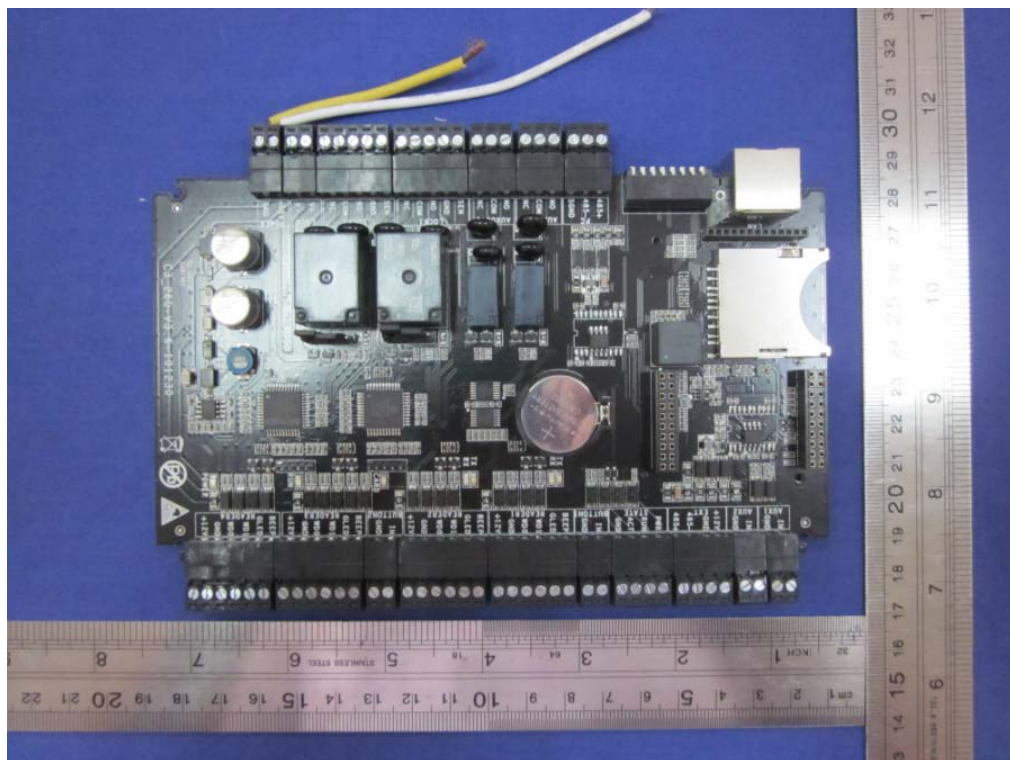
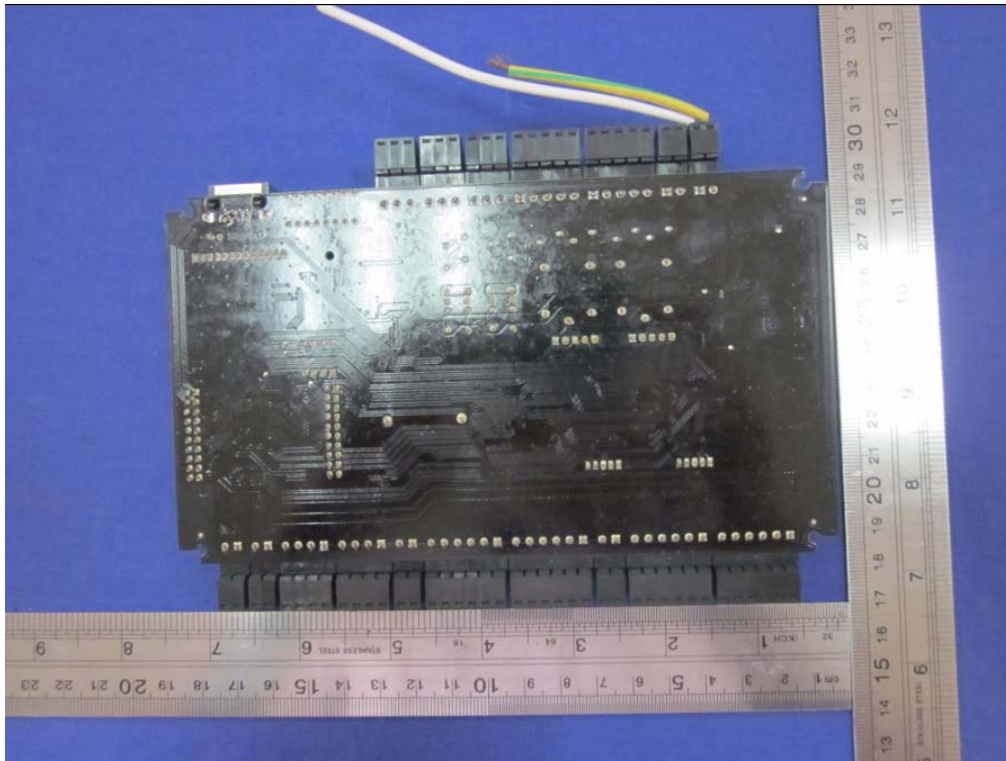



Photo 7



※※ End of Report ※※