

*Mobile Access,
TimeTec Smart Tripod Turnstile*
STS 2100B/2200B

Installation Manual

Contents

Chapter 1 • Product Introduction

1.1 Chassis and dimensions	1
1.2 Mechanical system of the swing barrier.....	2
1.3 Electronic control system	3
1.4 The working principle of swing barrier	3
1.5 System composition of the product	4
1.6 Product related parameters.....	4

Chapter 2 • The installation of the product

2.1 Installation notes.....	5
2.2 Installation position of the swing barrier.....	6
2.3 Cables Installation and Fixation	7

Chapter 3 • Menu Operation

3.1 Menu.....	8
3.2 Wiring diagram and function	13

Chapter 4 • Common failure analysis

17

Chapter 5 • Product maintenance

5.1 Chassis maintenance	18
5.2 Movement maintenance	18
5.3 Power maintenance.....	18

Chapter 1 • Product Introduction

1.1 Chassis and dimensions

STS2100B & 2200B series, with stainless steel housing, provide simple and beautiful design with anti-corrosion. It provides orderly and civilized passage to people while eliminating illegal personnel access. In case of emergency, it ensures timely evacuation channel smoothly and conveniently for personnel.

STS2100B appearance and dimensions are as shown in figure 1-2A :

STS2200B appearance and dimensions are as shown in figure 1-2B :

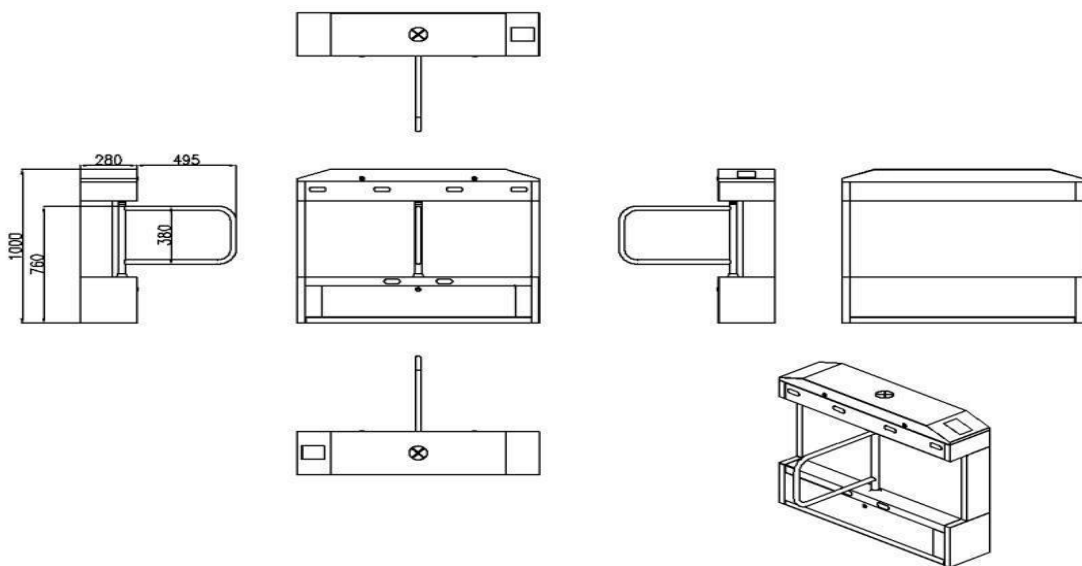

Figure1-2A

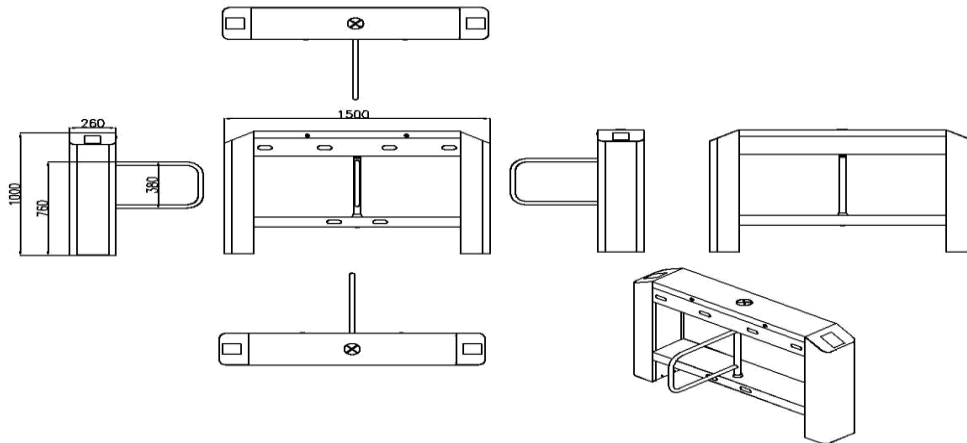

Figure1-2B

1.2 Mechanical system of the swing barrier

The mechanical system of a swing barrier turnstile includes the chassis and the core component. The chassis is a carrier where the direction indicator, the read-write device, the Infrared sensor, and the door locks is installed. The core component mainly consists of the electric motor, the frame, the belt, and the swing boom.

1.3 Electronic control system

The electronic control system of a swing barrier turnstile is mainly composed of the reader, master control panel, access controller, infrared sensor, direction indicator, alarm, and the transformer.

Reader : The reader reads the data onto the card and sends it to the controller.

Master control panel: The master control panel is the system's control center that receives signals from the reader and the photoelectric switch, performs logical judgment and processing of these signals, also sends executive commands to the direction indicator, electric motor and alarm.

Infrared sensor: It detects the position of a pedestrian and plays the role of safety protection.

Direction indicator: This indicator displays the current status of the sign of the channel, and directs the pedestrian to pass through the channel in a safe and orderly manner.

Alarm: The alarm gives an alarm message if the system detects any unauthorized entry to the channel.

1.4 The working principle of swing barrier

- After powered on, the system performs self-check. If no failure is detected, the machine starts to operate normally. If a failure is detected, the system displays related messages on the LCD Display screen so that the user can have a quick knowledge of and solve the problem.
- When the reader detects a valid card, the buzzer will give a nice audible prompt to the pedestrian, indicating that the card is being read successfully. And then, the reader sends signals to the access controller to request permission to pass through the passage. The access controller will send the signal to the master control panel.
- After receiving the signal from the access controller, the master control panel sends valid control signals to the direction indicator and the electric motor. And the direction arrow turns green.
- Pedestrians pass through the channel according to the direction indicator signs, infrared sensors detect the pedestrians pass through the whole process, and continue to send signal to the master control board until the pedestrian has been completely through the channel. If the pedestrian enters the channel but forgets to have the card read by the reader, or the card held

by the pedestrian is invalid, that the system will stop the pedestrian, and give an audible alarm until the pedestrian retreats from the channel. The pedestrian can pass through the channel only after a valid card is read by the card reader.

1.5 System composition of the product

The single-channel management system is composed of two single-core swing barrier turnstiles. The multi-channel management system is composed of two single-core barriers and multiple dual-core barriers.

Working modes of the system

To meet the requirements for use for different places, this system provides multiple working modes for the user. Including fire protection mode, normal working mode, testing mode,. The parameters can be set by using three built-in keypads ("ENT", "UP", and "DOWN") on the master control panel.

Option 16 in the menu is configurable using the values 0, 1, and 2.

If 0 is used, the system is being under the normal mode and does not detect the fire protection signals.

If the detected fire protection signal is a pulse signal, the value is set to 1. Once this pulse signal is

detected, the system will automatically open the barriers and stop actions until it is powered off to restart. If the detected fire protection signal is a continuous level signal, the value is set to 2. Once this continuous high-level signal is detected, the system will automatically open the barriers and then wait until this high-level signal disappears. After this signal disappears, the system automatically closes the barriers and falls into the normal working mode.

Option 15 can be used to set the self-testing mode of the system. If the value is set to 1, the system will enter the automatic testing mode. Under this mode, the system automatically figures out the parameters such as the inertia of the swing arm.

1.6 Product related parameters

Dimension(mm)	STS2100B : L=1200, W=280, H=1000 STS2200B : L=1500, W=280, H=1000		
Communication Interface	RS485	Input voltage	AC100-120V/200-240V,50-60Hz
Input control signal	Switching signal	output voltage	DC 24V
Time of opening/closing	0.6S(adjustable)	Relative humidity	5%-10%
Temperature	-28°C-60°C	Pass speed	RFID : Maximum 42/minute Fingerprint : Maximum 35/minute Face : Maximum 11/minute Vein : Maximum 23/minute
Infrared sensor	6	Working environment	indoor/Outdoor

Chapter 2 • The installation of the product

2.1 Installation notes

It is recommended that the swing barrier turnstile should be installed on a cement platform with 50mm to 100mm in height.

It is recommended that the swing barrier turnstile should not be used in corrosive environment.

Make sure the protective earth wire of the system is reliably connected to avoid personal injuries or other accidents.

After installation, check whether connection is reliable at the connecting points of the protective earth wire, at the connector assemblies and wiring points of the circuits, as well as at each movable part of the swing barrier turnstile. Any loose nuts, screws and other fasteners should be tightened in time to avoid swing barrier turnstile failures caused by long-time operations.

2.2 Installation position of the swing barrier

The installation position depends on the size of the swing barrier. If the swing barrier turnstile is installed near a wall, a distance from 100mm between the swing barrier turnstile and the wall needs to be reserved for ease of opening the top cover of the machine to perform maintenance and adjustment. The master and slave of a swing barrier turnstile may either form a channel, or form two channels with a swing barrier turnstile, as shown in figure 2-2;

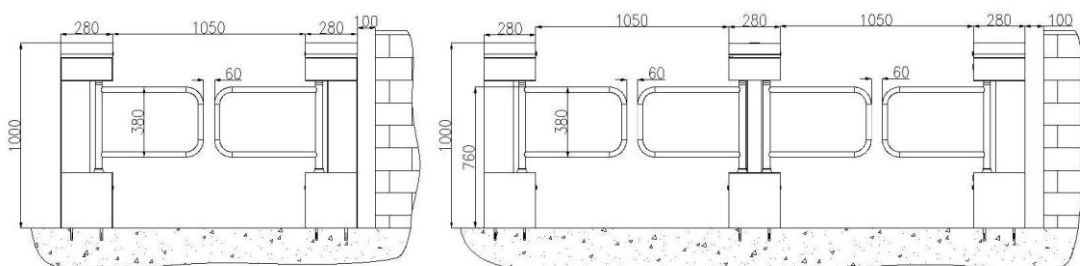

Figure2-2: STS2100B/2200B Single channel and dual channel

2.3 Cables Installation and Fixation

For the outlets of the concealed cables, please refer to the drawing showing the mounting holes. The input voltage for this swing barrier turnstile is AC100-120V/200-240V and its master and slave are connected by a 6-core cable. When installing this swing barrier turnstile, the user only needs to connect it to the corresponding ports. Note that the PVC conduits are buried 100mm below the ground, with the height of the exposed part not exceeding 100mm. In addition, the conduit outlet is bent back to prevent ingress of water into the conduit.

STS2100B/2200B installation holes and cabling positions as shown in Figure 2-3A.

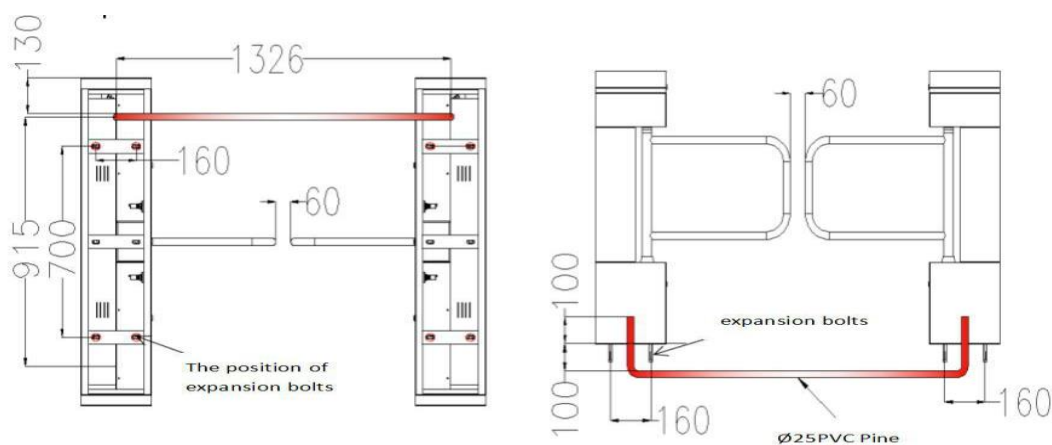

Figure 2-3A

Mark out the screw hole centers of the stand, and the edge of the chassis bases on the ground according to the sizes as shown on the figure 2-3A. Use a hammer drill to perforate M12 screw holes and then install the screws. Place the swing barrier turnstile according to the sizes and positions as shown in the figure before installation and fixation. Connect the online cables and perform the power-on test. If the test is OK, tighten the screws. It is recommended that a warning line was marked out on the ground after the machine is installed, so as to prompt the pedestrian to stand behind the warning line when swiping the card. As shown in Figure 2-3B:

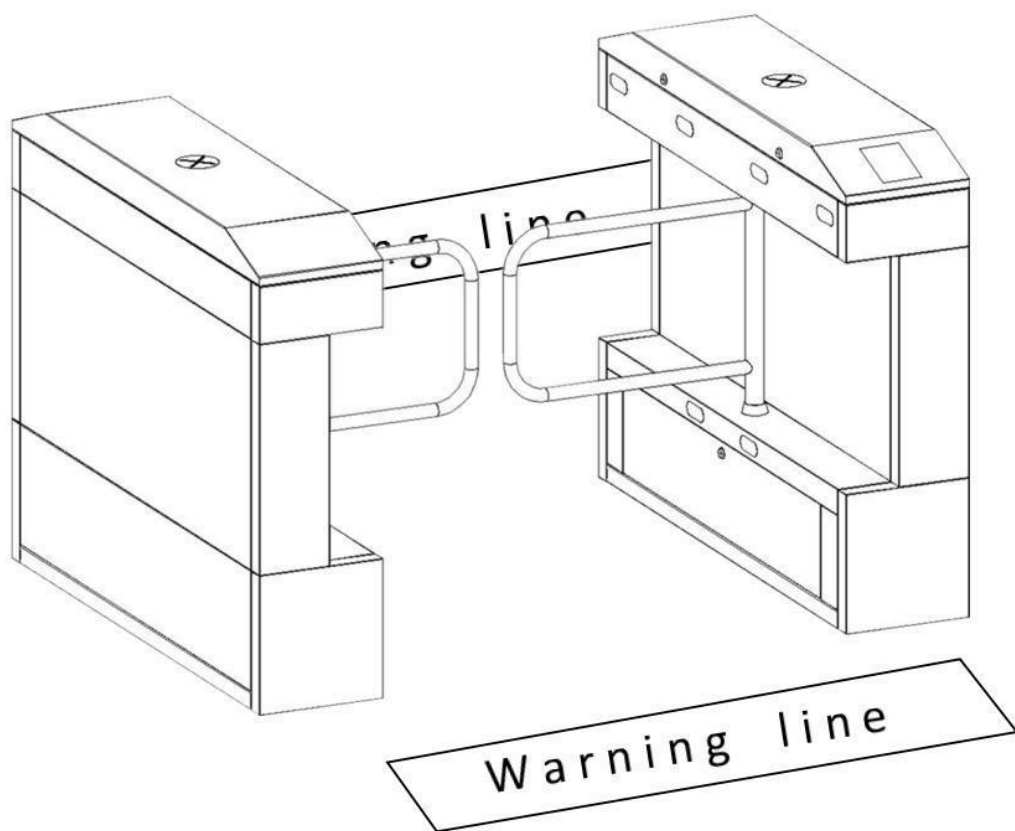

Figure 2-3B

Chapter 3 • Menu Operation

3.1 Menu

There are 4 keys on the LCD screen, including "UP", "DOWN", "ENT", and "ESC".

"UP" and "DOWN" are reset keys, each of which has two functions. When menu operations are not used, "UP" and "DOWN" can be used to open the barrier to left or right. When you press the "ENT" key, the system will prompt you to enter the password, the password is "UP" press two, "DOWN" press four, then press "ENT" to enter the menu operation system.

After the "ENT" key is pressed to enter the menu operation system, "UP" and "DOWN" cannot be used to open the barrier to left or right, but used for moving up and down on the menu to select an option.

Press "ENT" and the menu operation interface is displayed.
The menu has the following options:

- **Device mode:** This option is used to set the panel to be a master control panel or a slave control panel.

0: master

1: slave.

The master receives and judges the infrared signals. The slave does not receive or judge the infrared signals.

Specific operations are as follows :

Press "ENT" key to enter the menu and then press "UP/DOWN" to select the value you want. Finally press "ENT" to confirm.

- **Max motor ran time :** The electric motor stops running and an alarm is given when the actual running time to exceed this value. This value is set to prevent long-time operation of the motor under no load caused by a mechanical failure. The default value is 3 seconds.

Specific operations are as follows :

Press "ENT" key to enter the menu and then press "UP/DOWN" to select the value you want. Finally press "ENT" to confirm.

- **Open duration:** If the pedestrian swipes the card but does not pass through the channel, the system will automatically close the barrier after this time period has elapsed. The default value is 10 seconds.

Specific operations are as follows :

Press "ENT" key to enter the menu and then press "UP/DOWN" to select the function you want. Finally press "ENT" to confirm.

- **Opening mode:** The barrier can be opened in the following modes:

- 0: card swiping at both entry and exit.
- 1: card swiping at entry and infrared at exit.
- 2: infrared at entry and card swiping at exit.
- 3: infrared at both entry and exit.

Specific operations are as follows:

Press "ENT" key to enter the menu and then press "UP/DOWN" to select the function you want. Finally press "ENT" to confirm.

- **False direction entry:** This option is used to set whether to alarm and whether to make a corresponding judgment and give a voice message when a pedestrian enters the channel in the reserve direction.

- 0: cancel the function
- 1: immediately close the barrier and alarm once detect reverse entry.
- 2: only alarm once detect reverse entry.

Specific operations are as follows:

Press "ENT" key to enter the menu and then press "UP/DOWN" to select the function you want. Finally press "ENT" to confirm.

- **Anti tailgate:** This option is set to detect whether the pedestrian is tagged along, and to play a voice prompt or take other actions if the pedestrian is stalked by strangers.

- 0: cancel the detection
- 1: set the detection

Specific operations are as follows:

Press "ENT" key to enter the menu and then press "UP/DOWN" to select the function you want. Finally press "ENT" to confirm.

- **Set barrier position:**

- 1: zero position. (the position when the barrier is closed)
- 2: left open position. (the position when the barrier is open to left)
- 3: right open position. (the position when the barrier is open to right)

Methods for setting the zero position of the swing boom: First press "ENT" and the menu is displayed. Then press "UP" to move to Option 7 on the menu. Press "ENT" to make it available for value modification and then press "UP" to set the value to 1. Turn the swing boom to the desired zero position

(Perpendicular to the chassis, allowable deviation of 1 degrees) . Finally press "ENT" and the system gives a restart prompt. Zero calibration is finished.

Procedures for setting the left opening position of the swing boom: First press "ENT" and the menu is displayed. Then press "UP" to move to Option 7 on the menu. Press "ENT" to make it available for value modification and then press "UP" to set the value to 2. Move the swing boom of the gate to the desired position on the left-hand side. Finally press "ENT" and the system will record this position as the left open position.

Procedures for setting the right opening position of the swing boom: First press "ENT" and the menu is displayed. Then press "UP" to move to Option 7 on the menu. Press "ENT" to make it available for value modification and then press "UP" to set the value to 3. Move the swing boom of the gate to the desired position on the right-hand side. Finally press "ENT" and the system will record this position as the right opening position.

- **Language options:**

- 0 : simplified Chinese.
- 1 : English

Specific operations are as follows:

Press "ENT" key to enter the menu and then press "UP/DOWN" to select the function you want. Finally press "ENT" to confirm.

- **Opening speed :**

Setting the speed of opening the barrier .The speed ranges from 4 to 10.

Specific operations are as follows:

Press "ENT" key to enter the menu and then press "UP/DOWN" to select the function you want. Finally press "ENT" to confirm.

● **Close barrier time:** It is the delay after which system automatically closes the barrier after the pedestrian passes through the channel and triggers the last infrared sensor. The unit of this delay is second, the maximum value is 6. The default value is 0, which means that the barrier is closed immediately after the last infrared sensor is triggered.

Specific operations are as follows:

Press "ENT" key to enter the menu and then press "UP/DOWN" to select the function you want. Finally press "ENT" to confirm.

● **IR anti-pinch setting:**

0 : The infrared anti-pinch function is not activated (default by the system).

1 : The swing barriers stops moving if the third pair of infrared sensors in the passing direction is triggered.

2 : The swing Barrier rebound to open the door if the third pair of infrared sensors in the passing direction is triggered.

3 : The swing arm stops moving if the third pair and the fourth pair of infrared rays in the passing direction are triggered.

4 : The swing arm rebound to open the door if the third pair and the fourth pair of infrared rays in the passing direction are triggered.

5 : The swing arm stops moving if any infrared ray in the channel is triggered.

6 : The swing arm rebound to open the door if any infrared ray in the channel is triggered.

7 : The swing arm stops moving if the second pair and the third pair of infrared sensor along the passing direction, which are the middle infrared sensors in the channel, are triggered.

8 : The swing arm rebound to open the door if the second pair and the third pair of infrared rays in the passing direction, which are the middle infrared rays in the channel, are triggered.

Specific operations are as follows:

Press "ENT" key to enter the menu and then press "UP/DOWN" to select the function you want. Finally press "ENT" to confirm.

● **Memory function. Setting whether to record barrier opening memory:**

0: not to record. In other words, if the pedestrian does not pass through after the barriers is opened, the second opening signal is no longer received.

1: record. It means that opening of the barrier is recorded no matter how many opening signals are received. The default value is 0.

Specific operations are as follows

Press "ENT" key to enter the menu and then press "UP/DOWN" to select the function you want.

Finally press "ENT" to confirm.

- **Setting the speed of the electric motor:** Adjust the motor speed .Reasonable range is 4-6. If the set value is too small, the LCD screen may display such prompts as "there is a large resistance probably caused by looseness of the belt". If the value is excessively high, the swing arm may readily shake when returning to the zero position.

Specific operations are as follows:

Press "ENT" key to enter the menu and then press "UP/DOWN" to select the function you want.

Finally press "ENT" to confirm.

- **Setting the type of barrier machine:**

0: One lane two barriers

1: One lane one barrier

Specific operations are as follows:

Press "ENT" key to enter the menu and then press "UP/DOWN" to select the function you want.

Finally press "ENT" to confirm.

- **Machine mode:**

0: Default is 0, no meaning.

1: Auto test.Since the length of the swing arm and the system's resistance are different, this value should be used to initiate system testing before leaving factory so as to optimize the operation status of the swing boom.

2 : System initialization.Restore factory.

Specific operations are as follows:

Press "ENT" key to enter the menu and then press "UP/DOWN" to select the function you want.

Finally press "ENT" to confirm.

- **Fire alarm input:**

0: Cancel the fire alarm function.

1: Set the signal of the fire switch as a valid pulse signal with a duration exceeding 25 milliseconds. After the fire alarm signal is removed, the system can work normally only after the system is powered off and restarted.

2: Set the signal of the fire alarm switch as a long-term valid signal. If this signal is canceled, it means that the fire alarm signal disappears and the system automatically and normally works without being restarted.

Specific operations are as follows:

Press "ENT" key to enter the menu and then press "UP/DOWN" to select the function you want. Finally press "ENT" to confirm.

- **Barrier close speed:** The reasonable speed ranges from 3 to 10.

Specific operations are as follows:

Press "ENT" key to enter the menu and then press "UP/DOWN" to select the function you want. Finally press "ENT" to confirm.

3.2 Wiring diagram and function

Check circuit according to the following wiring diagram: The connection of slave :

Black→ GND , Green→TX, White→RX, Red→+24V

The connection of master :

Black→ GND , White→RX, Green→TX, Red→+24V

The yellow and orange are signal lines of the reader.

Swing Barrier Internal Wiring

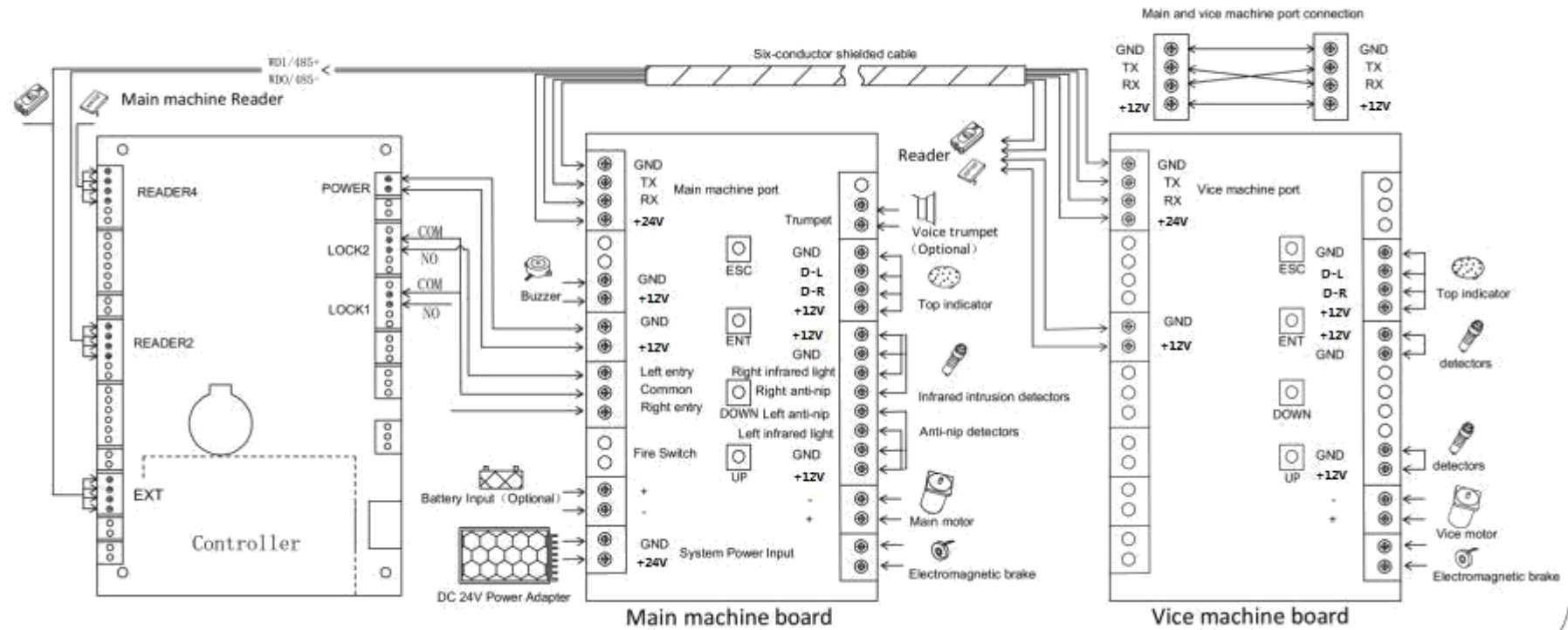

Swing Barrier Wiring with BLE2

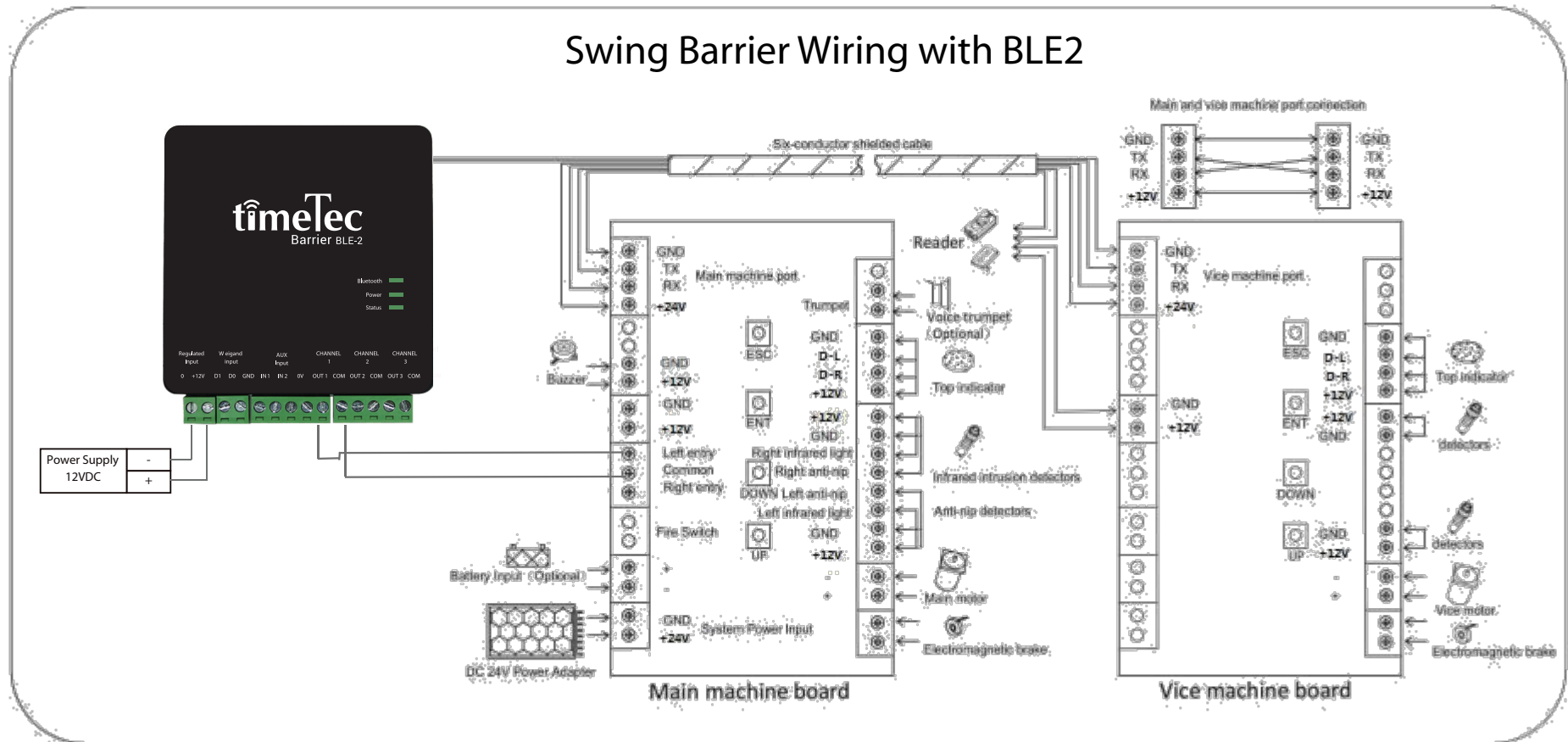

Functions of terminals at each zone:

System power input

The main voltage is changed by a transformer to 24V and supplied to the main panel.

Battery input: (optional)

After a power outage, the swing barrier of the machine is opened with power from the backup battery and no longer closed.

Fire switch

During emergencies ensuring users fast unencumbered exit to safety. Right entry, common, left entry: Control the barrier opens to left or right side. Access control power supply: Supply for the access board.

RS485 communication port

Receive external signals

Master/slave terminal

It is connected to the master and slave boards to transfer signals.

Electromagnetic brake

It is connected to the electromagnet inside the core component to prevent collision and pinch.

Connecting cable of the motor

It is connected to the motor and supplies power to the motor.

Left infrared detectors, left anti-pinch/right infrared detectors, right anti-pinch detectors

It detects the position of a pedestrian in the channel. It has the detecting and anti-pinch function.

Direction indicator board terminal

This terminal is connected to the LED board to indicate whether the pedestrian can pass through the chan

Chapter 4 • Common failure analysis

Number	Failure phenomena	Analysis and solution
1	Direction indicator no response or indication is not correct.	Check whether the connection to the roof lamp is correct or not.
2	After swipe the card there is only a swing arm action.	Check the type setting and the 6 core connection line of main and auxiliary machine.
3	Barrier opens after a long time without closing.	Check whether the time of the opening is too long.
4	Swing the arm swing at zero position.	This situation may be caused by the thirteenth sets of the menu is too large. to decrease the value of the thirteenth items may solve the problems.
5	"Serious malfunctions. Pendulum rod rotation is out of preset range,please do zero correction".	User needs to correct the zero position,left open position and right open position in seventh items.

Chapter 5 • Product maintenance

5.1 Chassis maintenance

The chassis is made up of 304 stainless steels. There may be rust stains on its surface after using for a long time. Regularly sand the surface along the grain softly and carefully, Coat the surface with anti-rust oil, Do not cover the infrared sensor.

5.2 Movement maintenance

Cut off power supply before maintenance. Open the door, clean surface dust, apply butter to the transmission mechanism. Check whether the belt is loose, if loose, adjust the position of the motor to make the belt tightening. Check and tighten others connection parts.

5.3 Power maintenance

Cut off power supply before maintenance. Check whether the plug is loose, if loose need to tightly it, do not replace the connection position at random, check whether the external power supply is exposed, timely wrapped, whether there is any leakage, timely treatment. Check the technical parameters of interface is normal, the aging of electronic components to be replaced.

(Attention: Above swing barrier maintenance must be maintained by professional personnel · Especially the movement and the electric control part, first cut off the power supply, ensure the operation safety.)

