

Installation Guide



Face ID 4d
Face Recognition System for
Door Access & Time Attendance

Step 1 Determine the Location and Positioning of the Installation

- Avoid installing the terminals in locations that has contact with a strong light source (e.g direct sunlight, spotlight, fluorescent light, etc)



- Avoid installing the terminals in locations prone to high moisture or condensation levels in the air
- The recommended installation height of the terminal from the ground is 1.2 meter.

Step 2 Mounting Terminals

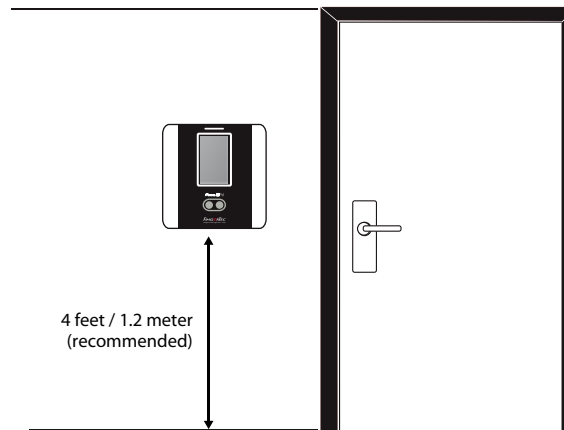

- After measuring the height accordingly and make relevant marking on the wall, drill the screws into the wall to secure the back plate.
- Attach the terminal to the back plate and tighten the screws. Refer to Appendix II for dimensions and measurements of installation.

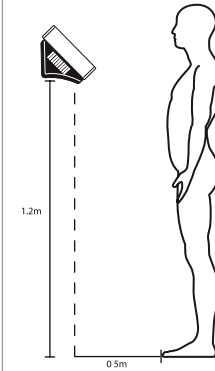

INSTALLATION TIPS:

A good installation location of Face ID 4 must

- 1 - Avoid sunlight
- 2 - Be 2 meters away from any light source e.g. ceiling direct fluorescent light
- 3 - Suggested 1.2m from the ground level (measure from ground to the camera)

Step 3 Wiring for Power Supply

Connection points for power and communication are available at the back of the terminal. Refer to the following diagrams for the correct installation.

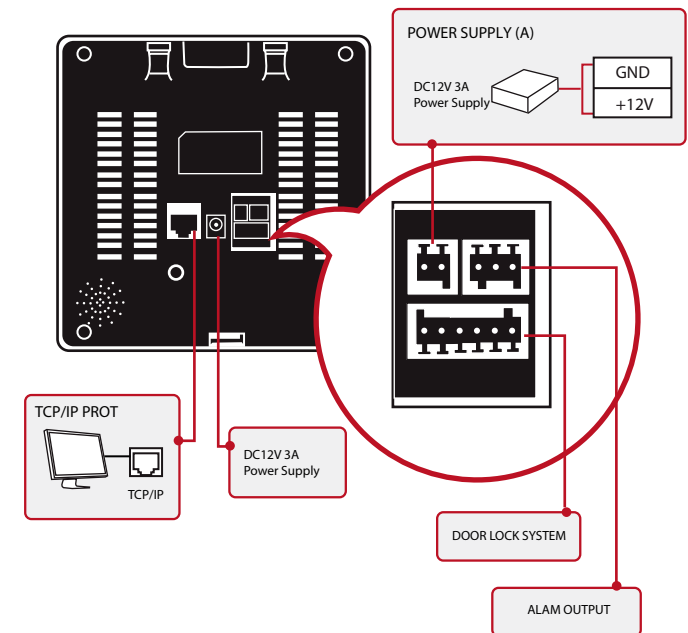

Step 4 Setting Up Data Communication

(Skip this step if you are using USB flash disk to transfer data)

The data communication ports are positioned at the rear of the terminals, please refer to the diagrams shown on Step 3 to determine the wiring. Plug the communication jacks to the corresponding ports.

TCP/IP – LAN Connection

For TCP/IP connection, plug the special RJ45 jack into the TCP/IP (LAN) Port of the terminal. Connect the other end (normal RJ45 jack) to the local area network hub or a PC. Configure the device ID, IP address, subnet mask and Gateway in the terminal (refer to the hardware user manual for details).

Step 5 Finalizing the Installation

1. Check that all cable connections are done correctly.
2. Attach the terminal to the corresponding back plates and tighten the screws to secure the terminal on the wall.
3. Switch on the power to the terminal.
4. Start using the terminal.

Other Accessories

FingerTec offers complementing accessories which can be used with your terminals. These optional accessories are available at <http://accessory.fingertec.com>

AdapTec Plus

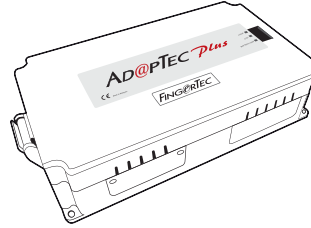

The AdapTec Plus is a 12VDC power supply inclusive of a 110~240VAC switching linear power. The AdapTec Plus supplies 12VDC power to the FingerTec terminal and door lock system as well as charges a 12VDC 7.0Ah backup battery simultaneously. During an event of a power failure, the back up battery automatically provides power to the terminal and maintains the door lock system. The AdapTec Plus also prevents a secured door from being opened if it has been tampered with.

Door Lock Accessories

FingerTec offers various door locks accessories to complement FingerTec door access product range.

Appendix I Power Supply & Door Lock System Wiring Diagrams

▶ Diagram 1 • Normally Close (NC)

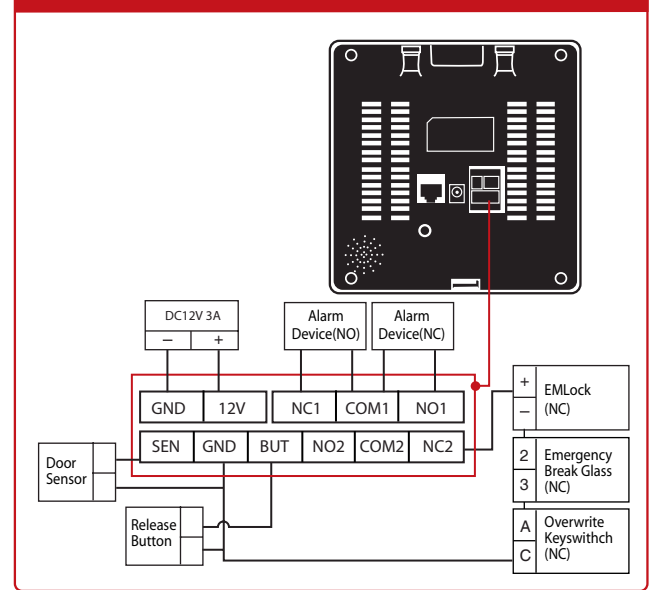

▶ Diagram 2 • Normally Open (NO)

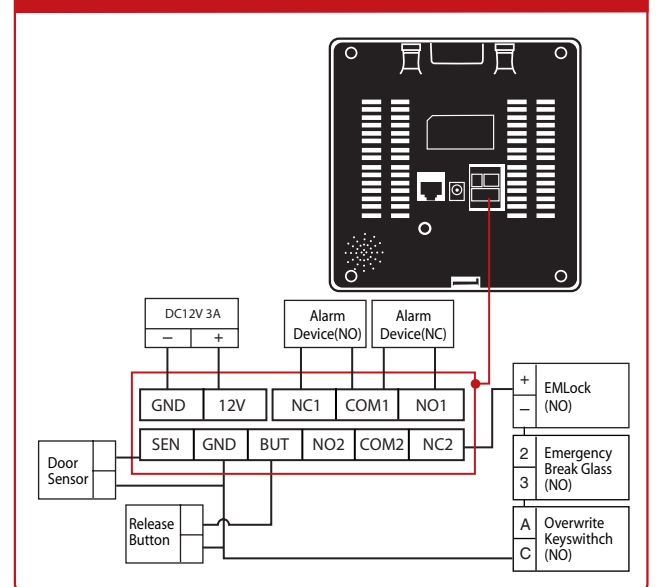

▶ Diagram 3 • Other Accessories

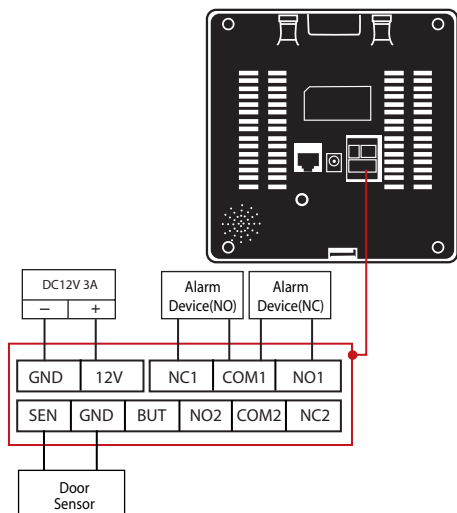

Door Lock Connectors

WIRING PORT	USAGE
SEN	Door Sensor (SEN-GND) Release button (BUT-GND)
GND	
BUT	
NO2	Dry Contact (independ-ent power supply for door lock) • NO type door lock (NO1-COM) • NC type door lock (NC1-COM) Power Contact (using power from terminal to power on door lock) • NO type door lock (NO1-GND) • NC type door lock (NC1-GND)
NC2	
COM2	Dry Contact (independ-ent power supply for door lock) • NO type door lock (NO1-COM) • NC type door lock (NC1-COM) Power Contact (using power from terminal to power on door lock) • COM1 - +12V
NC1	
COM1	Alarm output dry contact Independent power supply for alarm system • NO type alarm (NO1-COM1) • NC type alarm (NC1-COM1)
NO1	

Appendix I
Terminal Dimensions and Measurements

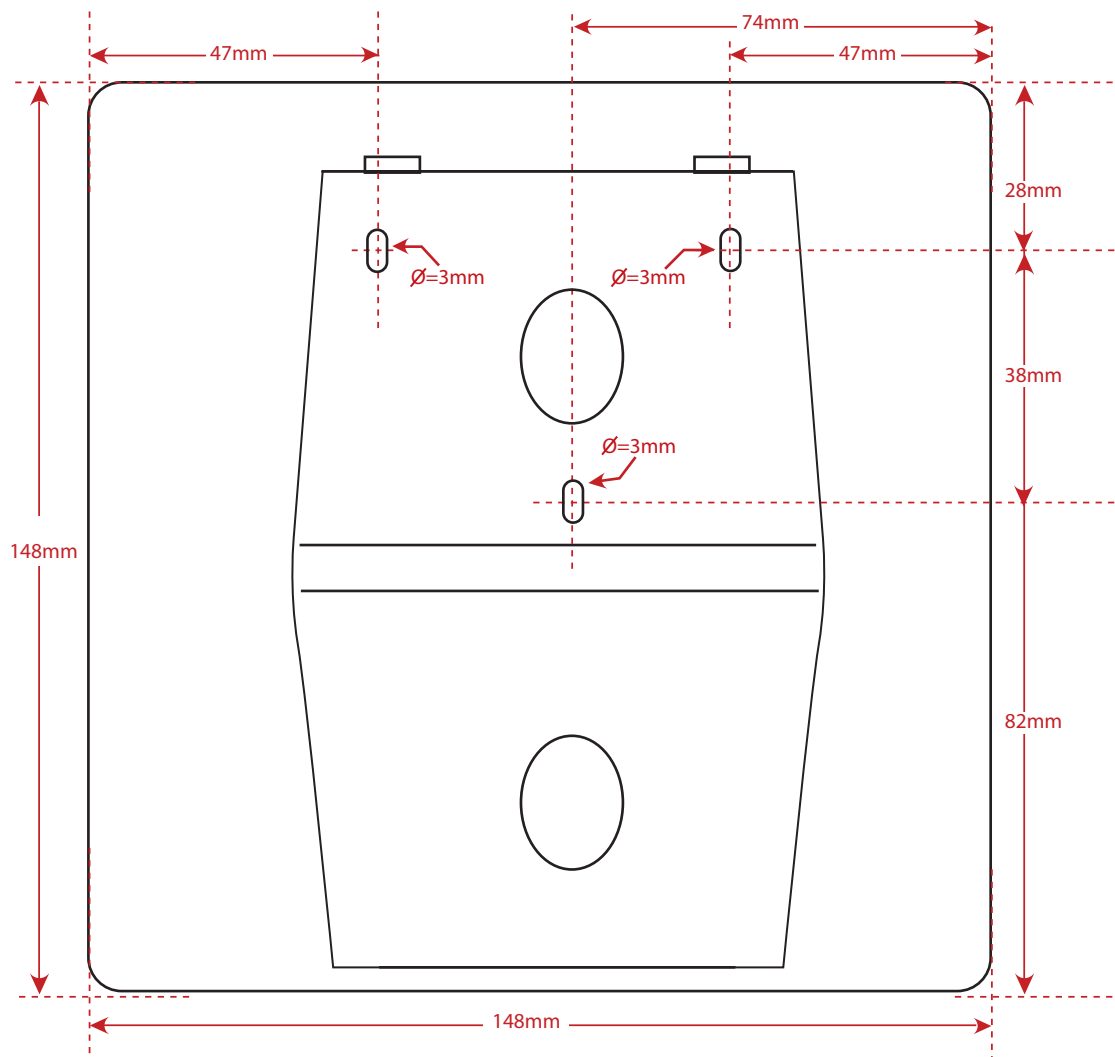

Front View of Back Plate