

Installation Guide

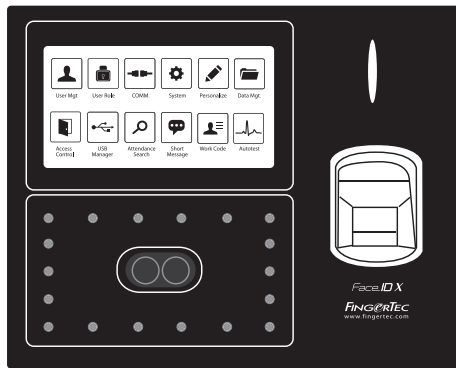

Face ID X

2-in-1 Face & Fingerprint Recognition Terminal

Step 1 Determine the Installation Location

- Avoid installing the terminals in locations that have contact with strong light source (e.g direct sunlight, spotlight, fluorescent light, etc)



- Avoid installing the terminals in locations with high moisture or condensation levels in the air
- The recommended installation height of the terminal from the ground to the camera is 1.2 meter.

Step 2 Mount Terminal on a Wall

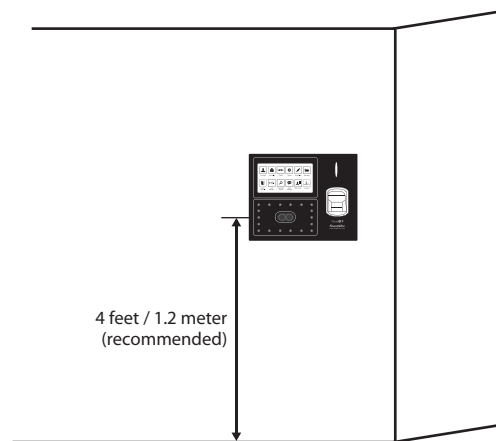

1. Avoid strong sunlight
2. Install the terminal 1.2m from the ground level (measure the height from the ground to the face camera)"

After measuring the height accordingly and make relevant markings on the wall, drill the screws into the wall to secure the back plate.

Attach the terminal to the back plate and tighten the screws.

Refer to Appendix II for dimensions and measurements of installation.

Step 3 Wiring for Power Supply

Use the power adapter provided in the package and insert the power adapter to the Power Port (A).

OR

Use power cables (black and red) to connect to a linear power supply with specifications of 12VDC 3A to Power Port (B).

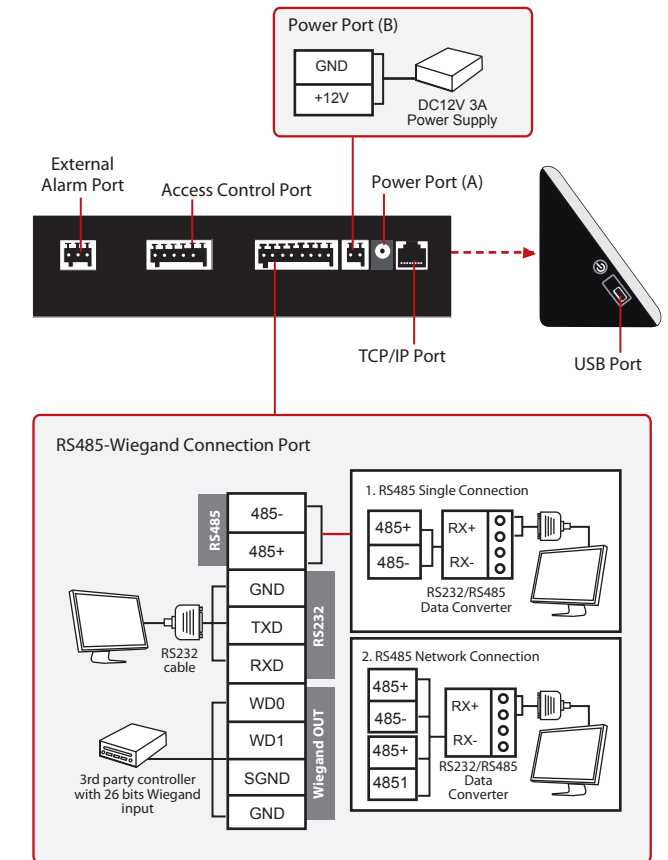

Step 4 Setting Up Data Communications

(Skip this step if you are using USB flash disk to transfer data)

The data communication ports are positioned at the rear of the terminal, please refer to the diagram shown on Step 3 to determine the wiring. Plug the communication jacks (TCP/IP, RS232 or RS485) to the corresponding ports.

TCP/IP – LAN Connection

For TCP/IP connection, plug the special RJ45 jack into the TCP/IP (LAN) Port of the terminal. Connect the other end (normal RJ45 jack) to the local area network hub or a PC. Configure the device ID, IP address, subnet mask and Gateway in the terminal (refer to the hardware user manual for details).

RS232 – Serial Port Connection

Plug the communication jack that is provided in the package to connect to the communication port of the terminal. Select wires with label RX, TX and GND, and connect the other end of these wires to a DB9 female connector. Configure the device ID and baudrate of the terminal (refer to the hardware user manual for details). Use the normal RS232 cable to plug into the RS232 port of the terminal.

RS485 – Serial Port Connection

Plug the communication jack that is provided in the package to connect to the communication port of the terminal. Select wires with label RS485+, RS485- and GND, and connect the other end of these wires to an RS232/485 data converter. Connect the other end of the data converter to a DB9 female connector. Configure the device ID and baudrate of the terminal (refer to the hardware user manual for details).

Step 5 Finalizing the installation

1. Check that all cable connections are done correctly.
2. Attach the terminal to the corresponding back plate, tighten the screws to fix the terminal on a wall.
3. Switch on the power to the terminal.
4. Start using it.

Other Accessories

Note: All Accessories are offered at <http://accessory.fingertec.com>

AdapTec Plus

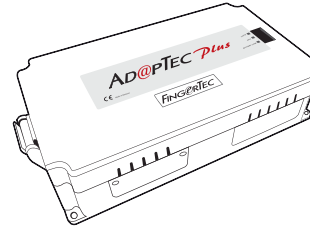

The AdapTec Plus is a 12VDC power supply inclusive of a 110~240VAC switching linear power. The AdapTec Plus supplies 12VDC power to the FingerTec terminal and door lock system as well as charges a 12VDC 7.0Ah backup battery simultaneously. During an event of a power failure, the back up battery automatically provides power to the terminal and maintains the door lock system. The AdapTec Plus also prevents a secured door from being opened if it has been tampered with.

Door Lock Accessories

FingerTec offers various door locks accessories to complement the door access product range.

FINGERTEC

Appendix I Power Supply & Door Lock System Wiring Diagrams

▶ Diagram 1 • Normally Close (NC)

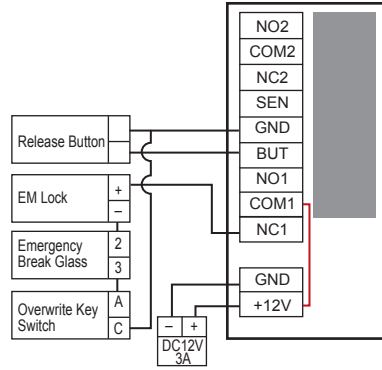

▶ Diagram 2 • Normally Open (NO)

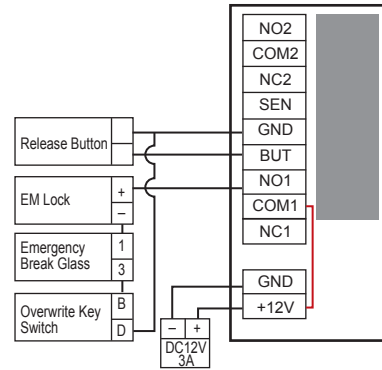

▶ Diagram 3 • Other Accessories

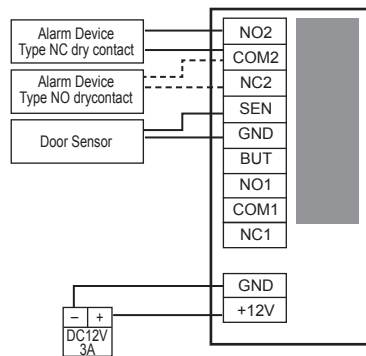

Use either Type NO or Type NC alarm device.

Door Lock Connectors

WIRING PORT	USAGE
NO2	Alarm System
COM2	NO Type – NO2 – COM2
NC2	NC Type – NC2- COM2
SEN	
GND	Door Sensor (SEN-GND)
BUT	Release Button (BUT-GND)
NO1	Dry Contact
NC1	(Independent power supply for door lock)
	• NO type door lock (NO1-COM1)
	• NC type door lock (NC1-COM1)
	Power Contact
	(Using power from terminal to power on door lock)
	• NO type door lock (NO1-GND)
	• NC type door lock (NC1-GND)
COM1	Dry Contact (independent power supply for door lock)
	• NO type door lock (NO1-COM1)
	• NC type door lock (NC1-COM1)
	Power Contact (using power from terminal to power on door lock)
	• COM1 - +12V

The terminal will trigger the alarm output (NO or NC) in the following situations:

- Door forced open (A door sensor must be installed)
- Door open time out (A door sensor must be installed)
- Terminal has been illegally dismantled

Appendix II Terminal Dimensions and Measurements

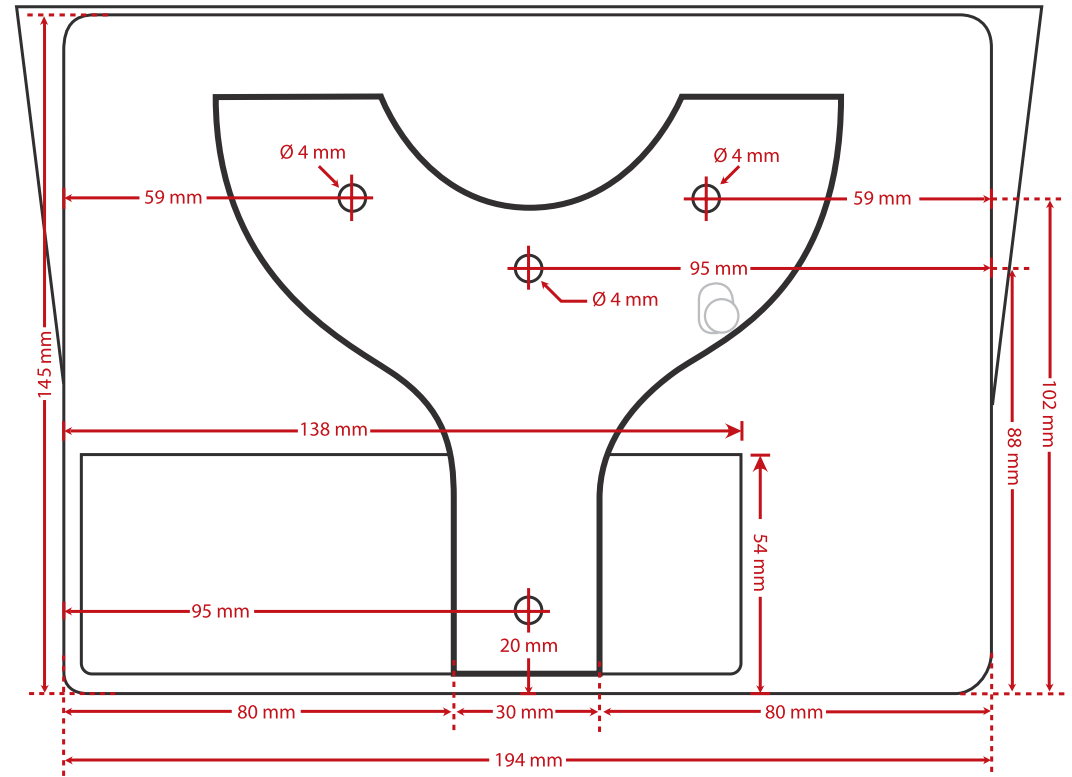

Front View of a Back Plate