

Installation Guides

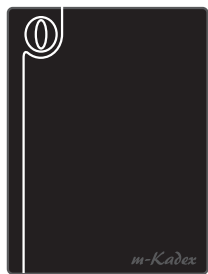

m-Kadex
Card Reader for Time Attendance &
Door Access Control System

Step 1 Determine the Location and Positioning of the Installation

- Avoid installing the terminals in locations with high moisture or condensation levels in the air
- The recommended installation height of the terminal from the ground is 1.2 meters.

Step 2 Mounting Terminals on a Wall

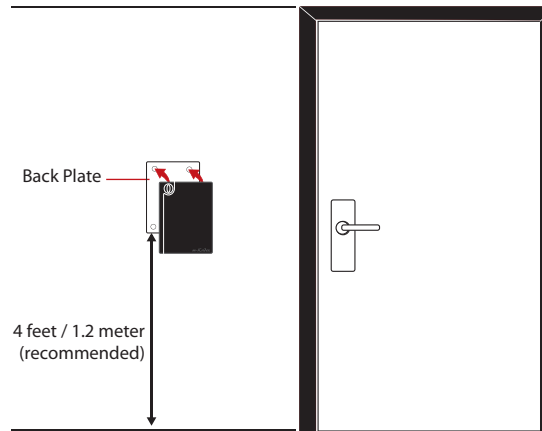

- After determining the height of the terminal from the ground level and have made the relevant marks on the wall, drill the screws into the wall to hang the back plate.

Refer to Appendix II for dimensions and measurements of installation.

Step 3 Wiring for Power Supply

The power input ports for these models are located at the rear of the terminals. There is no adapter plug supplied with the models, instead you need to source for power cables (red and black cables) to connect the power from the terminal to the AdapTec.

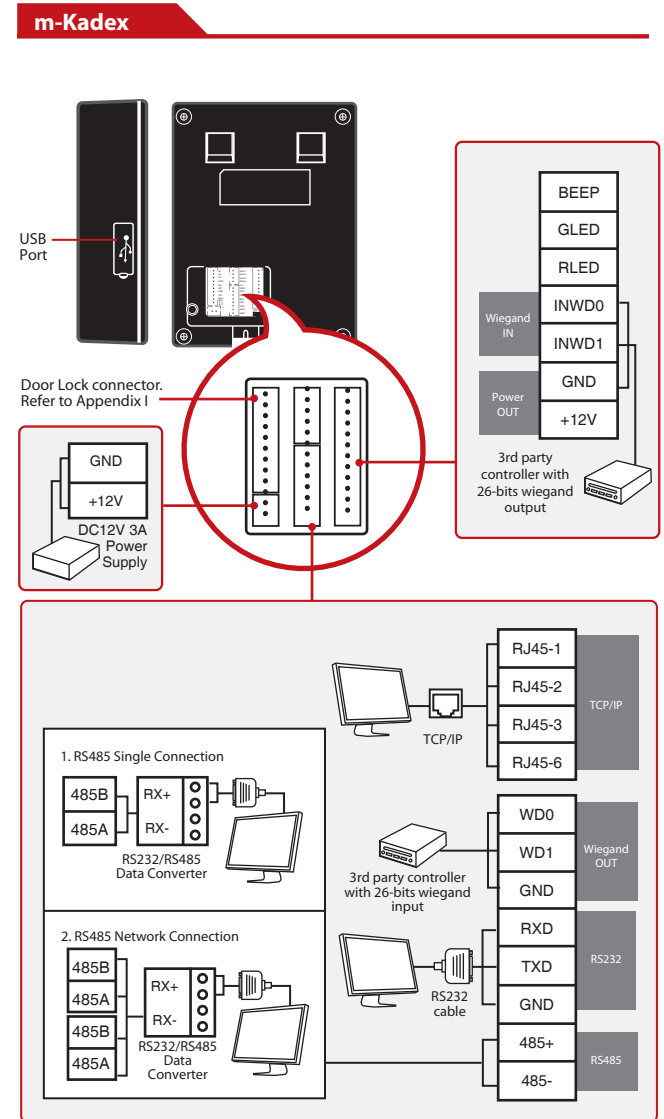

Step 4 Setting Up Data Communication

(Skip this step if you are using USB flash disk to transfer data)

The data communication ports are positioned at the rear of the terminals, please refer to the diagrams shown on Step 3 to determine the wiring. Plug the communication jacks (TCP/IP, RS232 or RS485) to the corresponding ports.

TCP/IP – LAN Connection

For TCP/IP connection, plug the special RJ45 jack into the TCP/IP (LAN) Port of the master terminal. Connect the other end (normal RJ45 jack) to the local area network hub or a PC. Configure the device ID, IP address, subnet mask and Gateway in the terminal (refer to the hardware user manual for details).

RS232 – Serial Port Connection

Plug the communication jack that is provided in the package to connect to the communication port of the master terminal. Select wires with label RX, TX and GND, and connect the other end of these wires to a DB9 female connector. Configure the device ID and baudrate of the terminal (refer to the hardware user manual for details). Use the normal RS232 cable to plug into the RS232 port of the terminal.

RS485 – Serial Port Connection

Plug the communication jack that is provided in the package to connect to the communication port of the terminal. Select wires with label RS485+, RS485- and GND, and connect the other end of these wires to an RS232/485 data converter. Connect the other end of the data converter to a DB9 female connector. Configure the device ID and baudrate of the terminal (refer to the hardware user manual for details).

Step 5 Finalizing the Installation

1. Check that all cable connections are done correctly.
2. Attach the terminal to the corresponding back plates and tighten the screws to secure the terminal on the wall.
3. Switch on the power to the terminal.
4. Start using the terminal.

Other Accessories

Note: All Accessories are offered at <http://accessory.fingertec.com>

AdapTec Plus

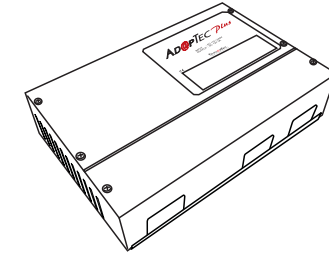

AdapTec Plus

The AdapTec AC is a 12VDC power supply inclusive of a 110~240VAC switching linear power. The AdapTec supplies 12VDC power to the FingerTec terminal and door lock system as well as charges a 12VDC 7.0Ah backup battery simultaneously. During an event of a power failure, the back up battery automatically provides power to the terminal and maintains the door lock system. The AdapTec Plus also prevents a secured door from being opened if it has been tampered with.

Enclosures

FingerTec offers enclosures to protect the terminals from being meddled with by unauthorized persons.

Door Lock Accessories

FingerTec offers various door locks accessories to complement FingerTec door access product range.

Appendix I Power Supply & Door Lock System Wiring Diagrams

► Diagram 1 • Normally Close (NC)

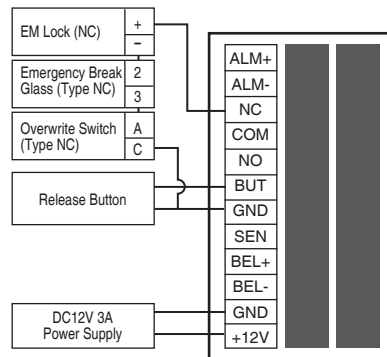

► Diagram 2 • Normally Open (NO)

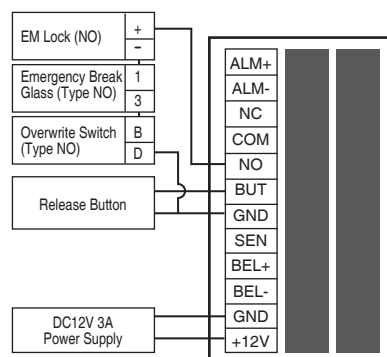

► Diagram 3 • Other Accessories

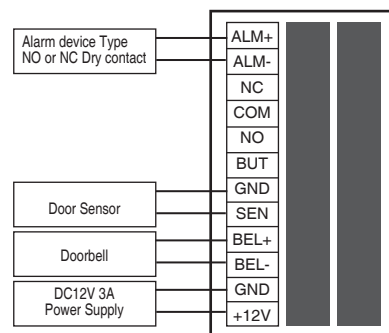

Door Lock Connectors

WIRING PORT	USAGE
ALM+	Alarm System (NO or NC Type – Check in Advance Options)
ALM-	
NC	Dry Contact (independent power supply for door lock) • NO type door lock (NO1-COM) • NC type door lock (NC1-COM)
NO	
	Power Contact (using power from terminal to power on door lock) • NO type door lock (NO1-GND) • NC type door lock (NC1-GND)
COM	
	Dry Contact (independent power supply for door lock) • NO type door lock (NO1-COM) • NC type door lock (NC1-COM)
BUT	
	Power Contact (using power from terminal to power on door lock) • COM1 - +12V
GND	
BUT	Door Sensor (SEN-GND)
GND	Release button (BUT-GND)
SEN	
BEL-	Door Bell
BEL+	

The terminal will trigger the alarm output (NO or NC) for the following situations:

- Door forced open (A door sensor must first be installed)
- Door open time out (A door sensor must first be installed)
- Terminal has been illegally dismantled

Appendix II Terminal Dimensions and Measurements

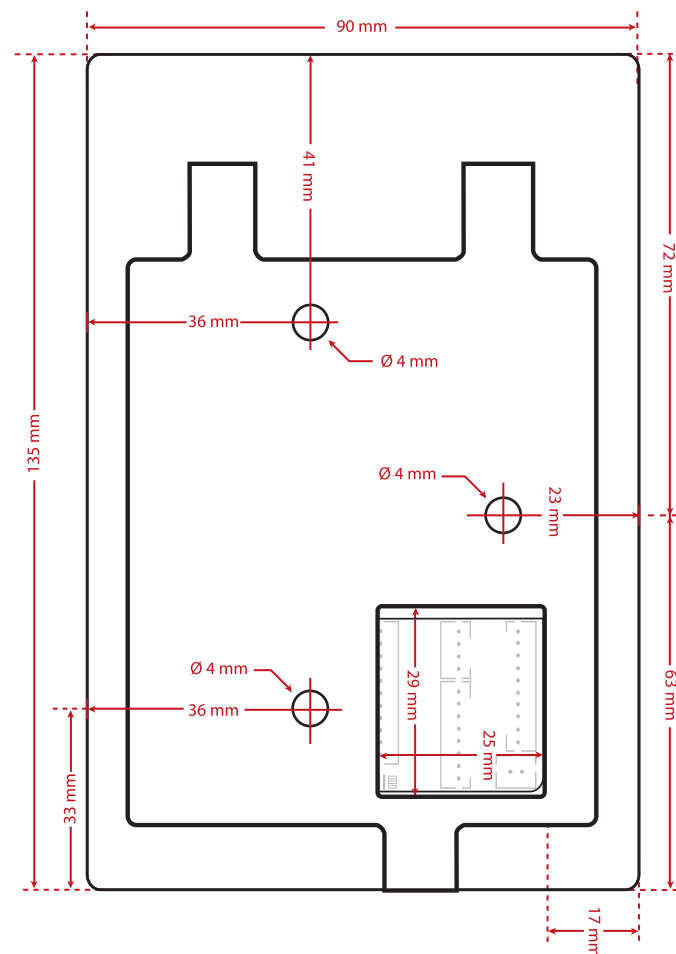

Front View of m-Kadex